



# A+ Server AS -1125HS-TNR



USER'S MANUAL

Revision 1.0d

The information in this User's Manual has been carefully reviewed and is believed to be accurate. The vendor assumes no responsibility for any inaccuracies that may be contained in this document, and makes no commitment to update or to keep current the information in this manual, or to notify any person or organization of the updates. Please Note: For the most up-to-date version of this manual, please see our website at [www.supermicro.com](http://www.supermicro.com).

Super Micro Computer, Inc. ("Supermicro") reserves the right to make changes to the product described in this manual at any time and without notice. This product, including software and documentation, is the property of Supermicro and/or its licensors, and is supplied only under a license. Any use or reproduction of this product is not allowed, except as expressly permitted by the terms of said license.

IN NO EVENT WILL Super Micro Computer, Inc. BE LIABLE FOR DIRECT, INDIRECT, SPECIAL, INCIDENTAL, SPECULATIVE OR CONSEQUENTIAL DAMAGES ARISING FROM THE USE OR INABILITY TO USE THIS PRODUCT OR DOCUMENTATION, EVEN IF ADVISED OF THE POSSIBILITY OF SUCH DAMAGES. IN PARTICULAR, SUPER MICRO COMPUTER, INC. SHALL NOT HAVE LIABILITY FOR ANY HARDWARE, SOFTWARE, OR DATA STORED OR USED WITH THE PRODUCT, INCLUDING THE COSTS OF REPAIRING, REPLACING, INTEGRATING, INSTALLING OR RECOVERING SUCH HARDWARE, SOFTWARE, OR DATA.

Any disputes arising between manufacturer and customer shall be governed by the laws of Santa Clara County in the State of California, USA. The State of California, County of Santa Clara shall be the exclusive venue for the resolution of any such disputes. Supermicro's total liability for all claims will not exceed the price paid for the hardware product.

FCC Statement: This equipment has been tested and found to comply with the limits for a Class A or Class B digital device pursuant to Part 15 of the FCC Rules. These limits are designed to provide reasonable protection against harmful interference when the equipment is operated in industrial environment for Class A device or in residential environment for Class B device. This equipment generates, uses, and can radiate radio frequency energy and, if not installed and used in accordance with the manufacturer's instruction manual, may cause harmful interference with radio communications. Operation of this equipment in a residential area is likely to cause harmful interference, in which case you will be required to correct the interference at your own expense.

California Best Management Practices Regulations for Perchlorate Materials: This Perchlorate warning applies only to products containing CR (Manganese Dioxide) Lithium coin cells. "Perchlorate Material-special handling may apply. See [www.dtsc.ca.gov/hazardouswaste/perchlorate](http://www.dtsc.ca.gov/hazardouswaste/perchlorate)".



WARNING: This product can expose you to chemicals including lead, known to the State of California to cause cancer and birth defects or other reproductive harm. For more information, go to [www.P65Warnings.ca.gov](http://www.P65Warnings.ca.gov).

The products sold by Supermicro are not intended for and will not be used in life support systems, medical equipment, nuclear facilities or systems, aircraft, aircraft devices, aircraft/emergency communication devices or other critical systems whose failure to perform be reasonably expected to result in significant injury or loss of life or catastrophic property damage. Accordingly, Supermicro disclaims any and all liability, and should buyer use or sell such products for use in such ultra-hazardous applications, it does so entirely at its own risk. Furthermore, buyer agrees to fully indemnify, defend and hold Supermicro harmless for and against any and all claims, demands, actions, litigation, and proceedings of any kind arising out of or related to such ultra-hazardous use or sale.

Manual Revision 1.0d

Release Date: October 04, 2024

Unless you request and receive written permission from Super Micro Computer, Inc., you may not copy any part of this document. Information in this document is subject to change without notice. Other products and companies referred to herein are trademarks or registered trademarks of their respective companies or mark holders.

Copyright © 2024 by Super Micro Computer, Inc.

All rights reserved.

**Printed in the United States of America**

# Preface

## About this Manual

This manual is written for professional system integrators and PC technicians. It provides information for the installation and use of the A+ Server AS -1125HS-TNR. Installation and maintenance should be performed by certified service technicians only.

Please refer to the server specifications page on our website for updates on supported memory, processors and operating systems (<http://www.supermicro.com>).

## Notes

For your system to work properly, please follow the links below to download all necessary drivers/utilities and the user's manual for your server.

- Supermicro product manuals: <http://www.supermicro.com/support/manuals/>
- Product drivers and utilities: <https://www.supermicro.com/wdl>
- Product safety info: [http://www.supermicro.com/about/policies/safety\\_information.cfm](http://www.supermicro.com/about/policies/safety_information.cfm)

If you have any questions, please contact our support team at:  
[support@supermicro.com](mailto:support@supermicro.com)

This manual may be periodically updated without notice. Please check the Supermicro website for possible updates to the manual revision level.

## Secure Data Deletion

A secure data deletion tool designed to fully erase all data from storage devices can be found on our website: [https://www.supermicro.com/about/policies/disclaimer.cfm?url=/wdl/utility/Lot9\\_Secure\\_Data\\_Deletion\\_Utility/](https://www.supermicro.com/about/policies/disclaimer.cfm?url=/wdl/utility/Lot9_Secure_Data_Deletion_Utility/)

## Warnings

Special attention should be given to the following symbols used in this manual.



**Warning!** Indicates important information given to prevent equipment/property damage or personal injury.



**Warning!** Indicates high voltage may be encountered when performing a procedure.

# Contents

## **Chapter 1 Introduction**

1.1 Overview.....	9
1.2 System Features .....	10
Front View .....	10
Drive Carrier Indicators.....	11
Control Panel.....	12
Rear View.....	13
1.3 System Architecture .....	15
Main Components .....	15
System Block Diagram.....	17
1.4 Motherboard Layout .....	18
Quick Reference Table.....	20

## **Chapter 2 Server Installation**

2.1 Overview.....	22
2.2 Unpacking the System .....	22
2.3 Preparing for Setup.....	22
Choosing a Setup Location.....	22
Rack Precautions .....	23
Server Precautions.....	23
Rack Mounting Considerations .....	23
Ambient Operating Temperature.....	23
Airflow .....	24
Mechanical Loading.....	24
Circuit Overloading .....	24
Reliable Ground.....	24
2.4 Installing the Rails .....	25
Identifying the Rails .....	25
Releasing the Inner Rail.....	26
Installing the Inner Rails .....	27
Installing the Outer Rails onto the Rack.....	28
2.5 Installing the Chassis into a Rack .....	29
Removing the Chassis from the Rack .....	30

---

---

## **Chapter 3 Maintenance and Component Installation**

3.1 Removing Power .....	31
3.2 Accessing the System.....	32
Removing the Top Cover.....	32
3.3 Processor and Heatsink Installation.....	33
3.4 Memory Installation .....	41
Memory Support.....	41
DIMM Module Population Sequence .....	43
DIMM Installation .....	44
DIMM Removal .....	44
3.5 Motherboard Battery.....	45
Battery Removal.....	45
Proper Battery Disposal .....	45
Battery Installation.....	45
3.6 Storage Drives.....	46
Installing Drives.....	46
Hot-Swap for NVMe Drives.....	48
3.7 System Cooling .....	49
Fans .....	49
Air Shrouds .....	50
3.8 Expansion Cards.....	51
Riser Cards .....	51
Installing M.2 Solid State Drives on Motherboard .....	53
3.9 AIOM Cards.....	54
3.10 Power Supply .....	55
3.11 Cable Routing Diagrams .....	56
Eight NVMe .....	56
Eight SATA .....	57
Eight SAS .....	58
Twelve NVMe .....	59
Twelve SATA .....	60
Twelve SAS .....	61
Eight NVMe + Four SATA .....	62
Eight NVMe + Four SAS.....	63

---

---

## **Chapter 4 Motherboard Connections**

4.1 Power Connections .....	64
4.2 Headers and Connectors .....	65
4.3 Input/Output Ports .....	67
I/O Ports.....	67
4.4 Jumper Settings .....	68
How Jumpers Work.....	68
4.5 LED Indicators.....	70

## **Chapter 5 Software**

5.1 Microsoft Windows OS Installation.....	71
5.2 Driver Installation.....	73
5.3 SuperDoctor® 5.....	74
5.4 IPMI .....	75
BMC ADMIN User Password .....	75

## **Chapter 6 Optional Components**

6.1 Storage Drive Options.....	76
6.2 Storage Control Cards .....	77
6.3 Power Supply Modules .....	78
6.4 Cable Management Arm.....	78
6.5 TPM Security Module.....	80

## **Chapter 7 Troubleshooting and Support**

7.1 Information Resources .....	81
Website .....	81
Direct Links for the AS -1125HS-TNR System.....	81
Direct Links for General Support and Information .....	81
7.2 Baseboard Management Controller (BMC).....	82
7.3 Troubleshooting Procedures .....	83
Before Power On .....	83
No Power .....	83
No Video .....	83
System Boot Failure.....	84
Memory Errors .....	84
The System Cannot Retain the Setup Configuration .....	84
When the System Becomes Unstable .....	85
7.4 Crash Dump Using BMC.....	86

---

---

7.5 UEFI BIOS Recovery .....	87
Overview .....	87
Recovering the UEFI BIOS Image.....	87
Recovering the Main BIOS Block with a USB Device.....	87
7.6 CMOS Clear .....	92
7.7 Where to Get Replacement Components .....	93
7.8 BMC.....	93
7.9 Reporting an Issue .....	94
Technical Support Procedures .....	94
Returning Merchandise for Service.....	94
7.10 Feedback.....	95

***Appendix A Standardized Warning Statements for AC Systems***

***Appendix B System Specifications***

---

---

## Contacting Supermicro

### Headquarters

Address: Super Micro Computer, Inc.  
980 Rock Ave.  
San Jose, CA 95131 U.S.A.

Tel: +1 (408) 503-8000

Fax: +1 (408) 503-8008

Email: marketing@supermicro.com (General Information)  
Sales-USA@supermicro.com (Sales Inquiries)  
Government\_Sales-USA@supermicro.com (Gov. Sales Inquiries)  
support@supermicro.com (Technical Support)  
RMA@supermicro.com (RMA Support)  
Webmaster@supermicro.com (Webmaster)

Website: [www.supermicro.com](http://www.supermicro.com)

### Europe

Address: Super Micro Computer B.V.  
Het Sterrenbeeld 28, 5215 ML  
's-Hertogenbosch, The Netherlands

Tel: +31 (0) 73-6400390

Fax: +31 (0) 73-6416525

Email: Sales\_Europe@supermicro.com (Sales Inquiries)  
Support\_Europe@supermicro.com (Technical Support)  
RMA\_Europe@supermicro.com (RMA Support)

Website: [www.supermicro.nl](http://www.supermicro.nl)

### Asia-Pacific

Address: Super Micro Computer, Inc.  
3F, No. 150, Jian 1st Rd.  
Zhonghe Dist., New Taipei City 235  
Taiwan (R.O.C)

Tel: +886-(2) 8226-3990

Fax: +886-(2) 8226-3992

Email: Sales-Asia@supermicro.com.tw (Sales Inquiries)  
Support@supermicro.com.tw (Technical Support)  
RMA@supermicro.com.tw (RMA Support)

Website: [www.supermicro.com.tw](http://www.supermicro.com.tw)

# Chapter 1

## Introduction

### 1.1 Overview

This chapter provides a brief outline of the functions and features of the SuperServer AS -1125HS-TNR. An overview of the system is listed below.

System Overview	
<b>Motherboard</b>	H13DSH
<b>Chassis</b>	CSE-HS119-R1K24P2-A
<b>Processor Support</b>	Dual AMD EPYC™ 9004/9005 (Motherboard revision 2.0 or above is required) Series processor in SP5 socket and a Thermal Design Power (TDP) unit up to 400 W* (*Depending on thermal validation and system configuration. Contact a Supermicro representative for details.)
<b>Memory</b>	24 DIMM slots with 1DPC that support up to 6 TB of ECC DDR5/3DS RDIMM at 4800 MT/s (AMD EPYC™ 9004 Series Processor) up to 9 TB of ECC DDR5/3DS RDIMM at 6000 MT/s (Motherboard revision 2.0 or above is required and AMD EPYC™ 9005 series only)
<b>Chipset</b>	System on Chip
<b>Drive Support</b>	Eight 2.5" SAS/SATA/NVMe drives (additional cables required) Optional additional four 2.5" SAS/SATA/NVMe drives Two M.2 NVMe PCIe 3.0 x4 in the 2280 and 22110 form factors for boot drive
<b>Expansion Slots</b>	Two PCIe 5.0 x16 FH, 10.5"L One PCIe 5.0 x16 FHHL
<b>I/O Ports</b>	One AIOM slot for flexible networking (OCP 3.0 compatible) One RJ45 dedicated BMC LAN port Three USB 3.2 Gen 1 ports (one front, two rear) One VGA port (1 rear)
<b>System Cooling</b>	Eight 4-cm heavy duty fans with optimal fan speed control Two air shrouds
<b>Power</b>	Two redundant power supplies: 1200 W (Titanium Level)
<b>Form Factor</b>	1U Rackmount 1.7 x 17.2 x 29.4 in / 43 x 437 x 747 mm (H x W x D)

**Notes:** A Quick Reference Guide can be found on the product page of the Supermicro website. The following safety models associated with the AS -1125HS-TNR have been certified as compliant with UL or CSA: HS119-R9H13, HS119-R12H13, HS119-R16H13, HS119-R20H13, HS119-R26H13, HS119-R13DH13, HS119-R16DH13, HS119-R20DH13, HS119-9, HS119-12, HS119-16, HS119-20, HS119-26, HS119-13D, HS119-16D, HS119-20D.

## 1.2 System Features

The following views of the system display the main features. Refer to [Appendix B](#) for additional specifications.

### Front View

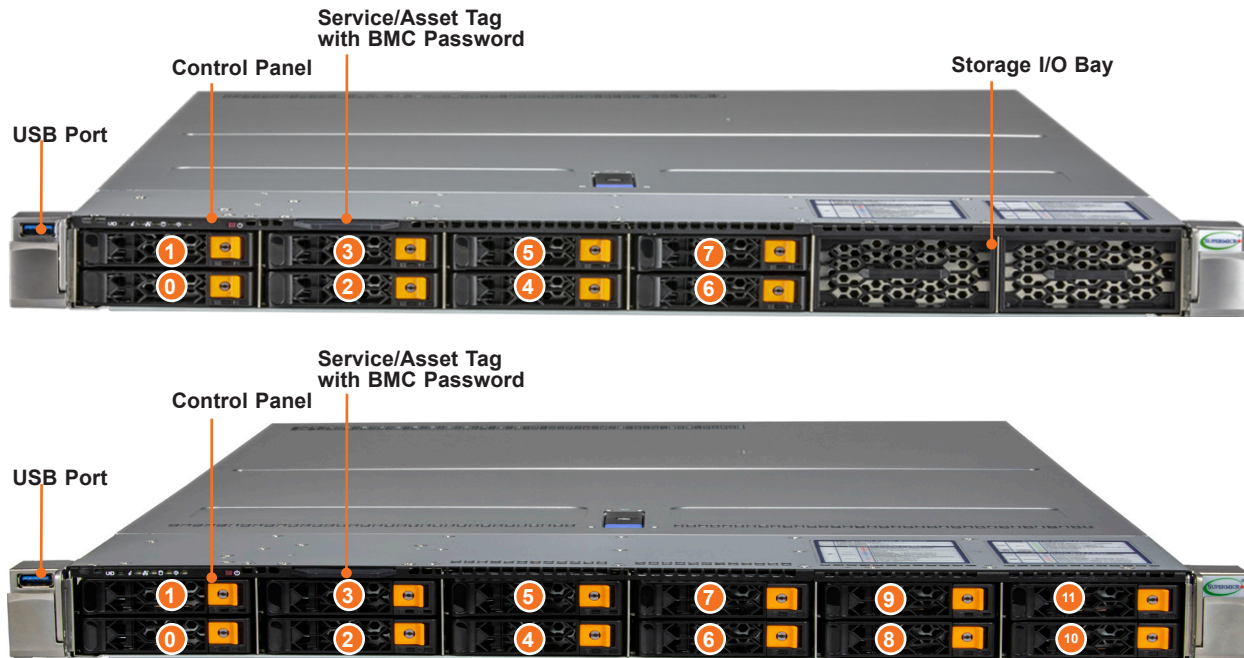

Figure 1-1. Front Views

System Features: Front	
Feature	Description
USB	One USB 3.2 Gen 1 port
Control Panel	One control panel (see <a href="#">Control Panel</a> for details)
Storage I/O Bay	Additional storage I/O bays
Asset Tag	Service/Asset Tag with BMC Password Reset

Logical Storage Drive Numbers	
Item	Description
0 _ 3	Four hot-swap 2.5" NVMe/SATA/SAS drive bays (NVMe from CPU1)
4 _ 7	Four hot-swap 2.5" NVMe/SATA/SAS drive bays (NVMe from CPU2)
8 _ 11	Optional four hot-swap 2.5" NVMe/SATA/SAS drive bays (NVMe from CPU2)

\*See section 3.11 for optional configurations and part numbers.

### Drive Carrier Indicators

Each drive carrier has two LED indicators: an activity indicator and a status indicator. For RAID configurations using a controller, the meaning of the status indicator is described in the table below. For OS RAID or non-RAID configurations, some LED indications are not supported, such as hot spare.

Drive Carrier LED Indicator			
	Color	Blinking Pattern	Behavior for Device
<b>Activity LED</b>	Blue	Solid On	Idle SAS/NVMe drive installed
	Blue	Blinking	I/O activity
	Off		Idle SATA drive installed
<b>Status LED</b>	Red	Solid On	Drive failure
	Red	Blinking at 1 Hz	Rebuilding drive
	Red	Blinking with two blinks and one stop at 1 Hz	Hot spare for drive
	Red	On for five seconds, then off	Power on for drive
	Red	Blinking at 4 Hz	Identify drive
	Green	Solid On	Safe to remove NVMe drive
	Amber	Blinking at 1 Hz	Do not remove NVMe drive

## Control Panel

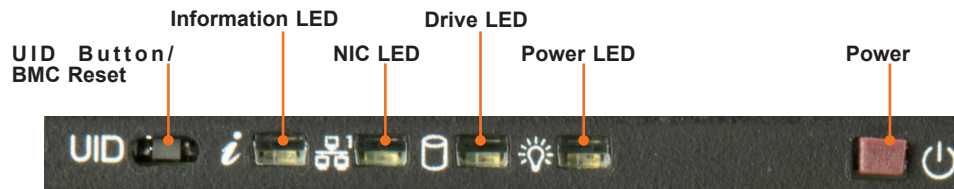

Figure 1-2. Control Panel

Control Panel Features	
Feature	Description
UID button/ BMC reset	The unit identification (UID) button turns on or off the blue light function of the Information LED. This button can also be used to reset the BMC.
Information LED	Alerts operator to several states, as noted in the table below.
NIC LED	Indicates network activity on LANs when flashing.
Drive LED	Indicates activity on the storage drives when flashing.
Power LED	Steady on – Power on Blinking at 4 Hz – Checking BIOS/BMC integrity Blinking at 4 Hz and "i" LED is blue – BIOS firmware updating Two blinks at 4 Hz, one pause 2 Hz and "i" LED blue – BMC firmware updating Blinking at 1 Hz and "i" LED red – Fault detected
Power button	The main power switch applies or removes primary power from the power supply to the server but maintains standby power. Hold for four seconds to force a shut-down.

Information LED	
Color, Status	Description
Red, solid	An overheat condition has occurred.
Red, blinking at 1 Hz	Fan failure, check for an inoperative fan.
Red, blinking at 0.25 Hz	Power failure, check for a non-operational power supply.
Red, solid, with Power LED blinking green	Fault detected
Blue and red, blinking at 10 Hz	Recovery mode
Blue, solid	UID has been activated locally to locate the server in a rack environment.
Blue, blinking at 1 Hz	UID has been activated using the BMC to locate the server in a rack environment.
Blue, blinking at 2 Hz	BMC is resetting
Blue, blinking at 4 Hz	BMC is setting factory defaults
Blue, blinking at 10 Hz with Power LED blinking green	BMC/BIOS firmware is updating

## Rear View

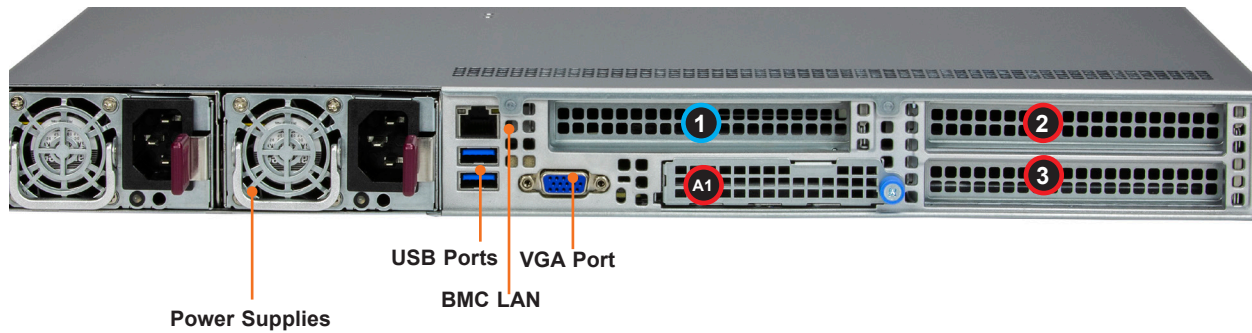

Figure 1-3. System: Rear View

System Features: Rear	
Feature	Description
Power Supplies	Two redundant power supply modules, PWS1 on the left, PWS2 on the right
USB	Two USB 3.2 Gen 1 ports
BMC LAN Port	One RJ45 dedicated BMC LAN port
VGA	VGA Port

Expansion Card Slots	
Item	Description (all PCIe 5.0)
A1	x16 AIOM Slot (OCP 3.0 Compatible)
1	x16 Slot (FH, 6.6"L)
2	x16 Slot (FH, 10.5"L)
3	x16 Slot (FH, 10.5"L)

\*Expansion slot capabilities are affected by the storage drive configurations.

CPU1 CPU2

<b>Power Supply Indicators</b>		
<b>Power Supply Condition</b>	<b>Green LED</b>	<b>Amber LED</b>
No AC Power to Power Supply	OFF	OFF
Power Supply critical events causing a shutdown/ failure/ OCP/ OVP/ Fan Fail/ OTP/ UVP	OFF	Amber LED
Power Supply Warning Events Where the power supply continues to operate; High temperature; Over voltage; under voltage, etc.	OFF	1Hz Blink Amber
AC present only 12VSB ON (PS OFF)	1Hz Blink Green	OFF
Output ON and OK	Green	OFF
AC cord unplugged and in redundant mode	OFF	Amber

## 1.3 System Architecture

This section covers the locations of the system's main components, a system block diagram, and a motherboard layout with the connectors and jumpers called out.

### Main Components

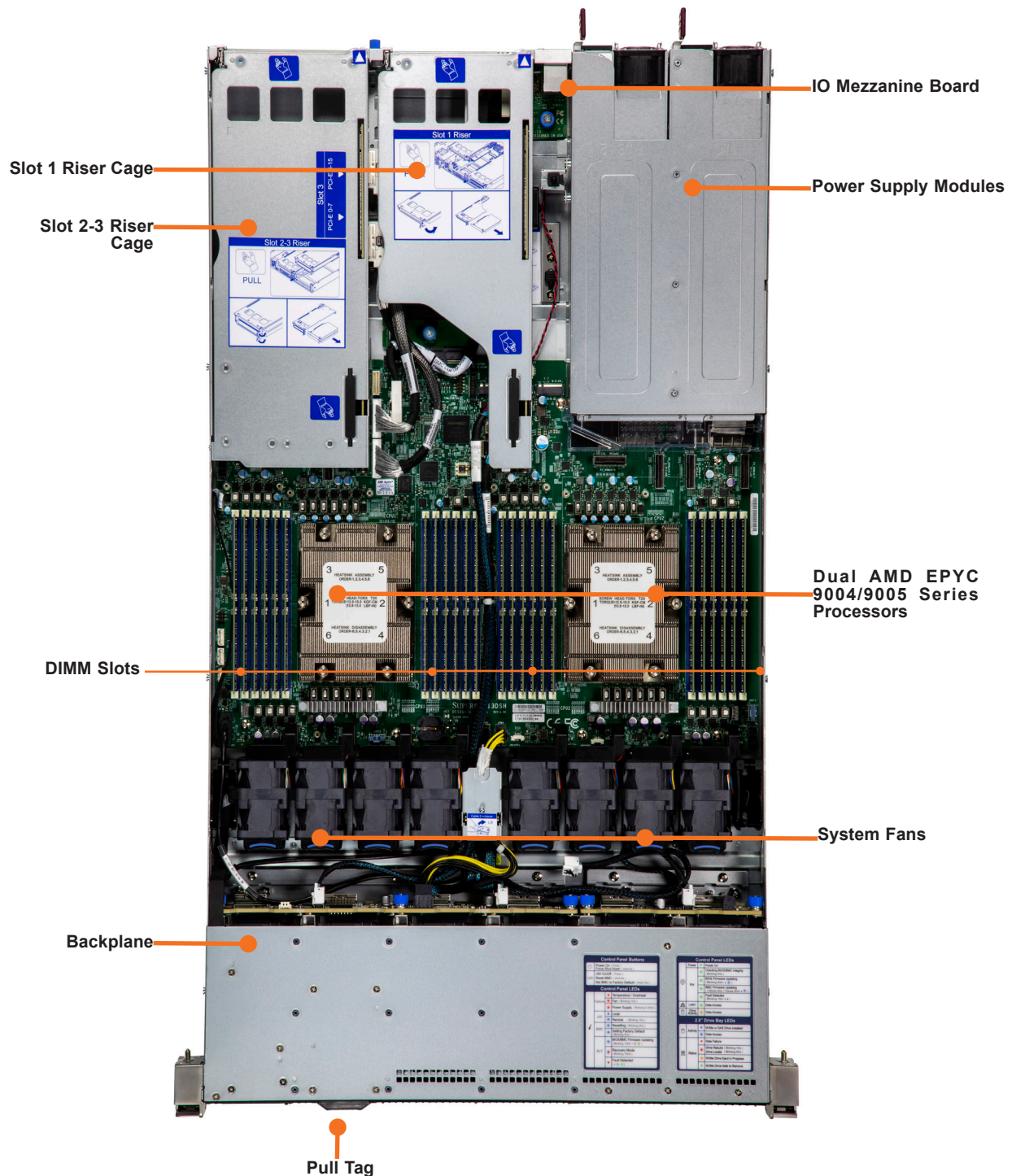

Figure 1-4. Main Component Locations

System Features: Top	
Feature	Description
Power Supply	Dual redundant modules, PWS-1K24A-1R
DIMM slots	24 DIMM slots to support up to 6 TB 3DS ECC RDIMM DDR5-4800 Hz memory
Processor	Dual AMD EPYC™ 9004/9005 (Motherboard revision 2.0 or above is required) Series Processor in SP5 socket
System Fans	Eight 4-cm dual counter-rotating PWM fans, FAN-0216L4-1
Pull Tag	Pull tag with serial number / BMC ADMIN password
Backplane	Eight SAS/SATA/NVMe storage device backplane, BPN-NVME5-HS119N-S8L
Slot 1 Riser Cage	Riser Cage for one PCIe slot with riser card RSC-H-6G5L
Slot 2-3 Riser Cage	Riser Cage for two PCIe slots with riser card RSC-H-66G5L

## System Block Diagram

The block diagram below shows the connections and relationships between the subsystems and major components of the overall system.

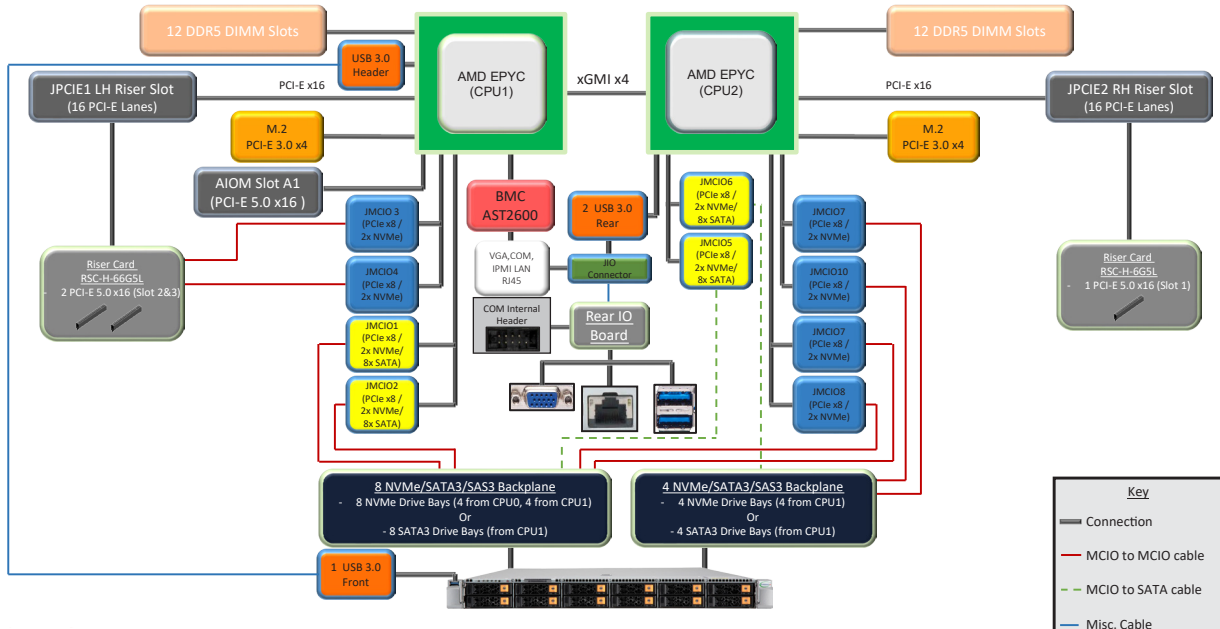

Figure 1-5. System Block Diagram

## 1.4 Motherboard Layout

Below are the layouts of the H13DSH motherboard with jumper, connector, and LED locations shown. There are two revisions of the layout. Figure 1.6 for Layout Revision 1.01A and Figure 1.7 for Layout Revision 1.10/2.0.

See the table on the following page for descriptions. For detailed descriptions, pinout information, and jumper settings, refer to [Chapter 4](#) or the [Motherboard Manual](#).

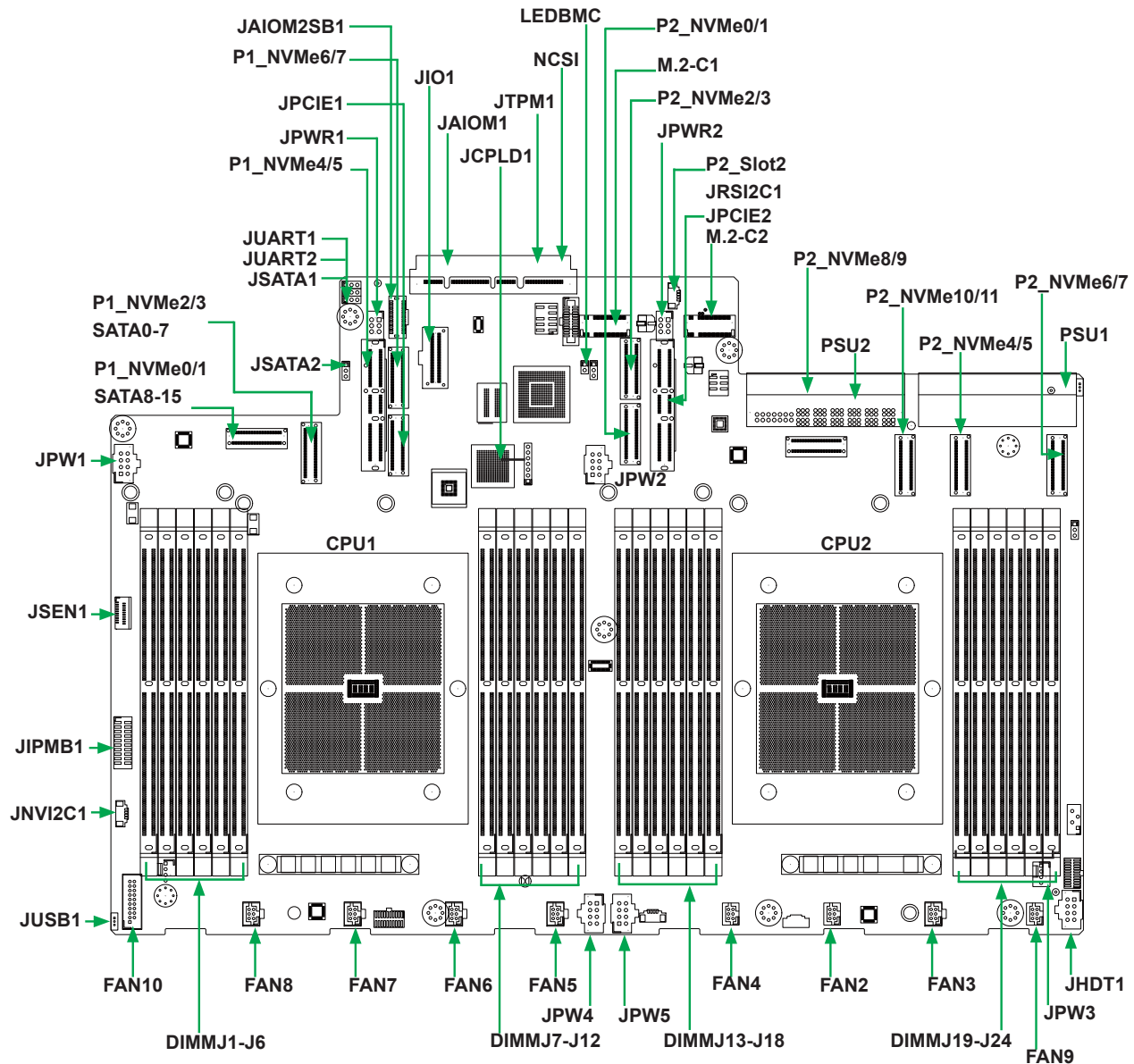

Figure 1-6. Motherboard Layout Revision 1.01A

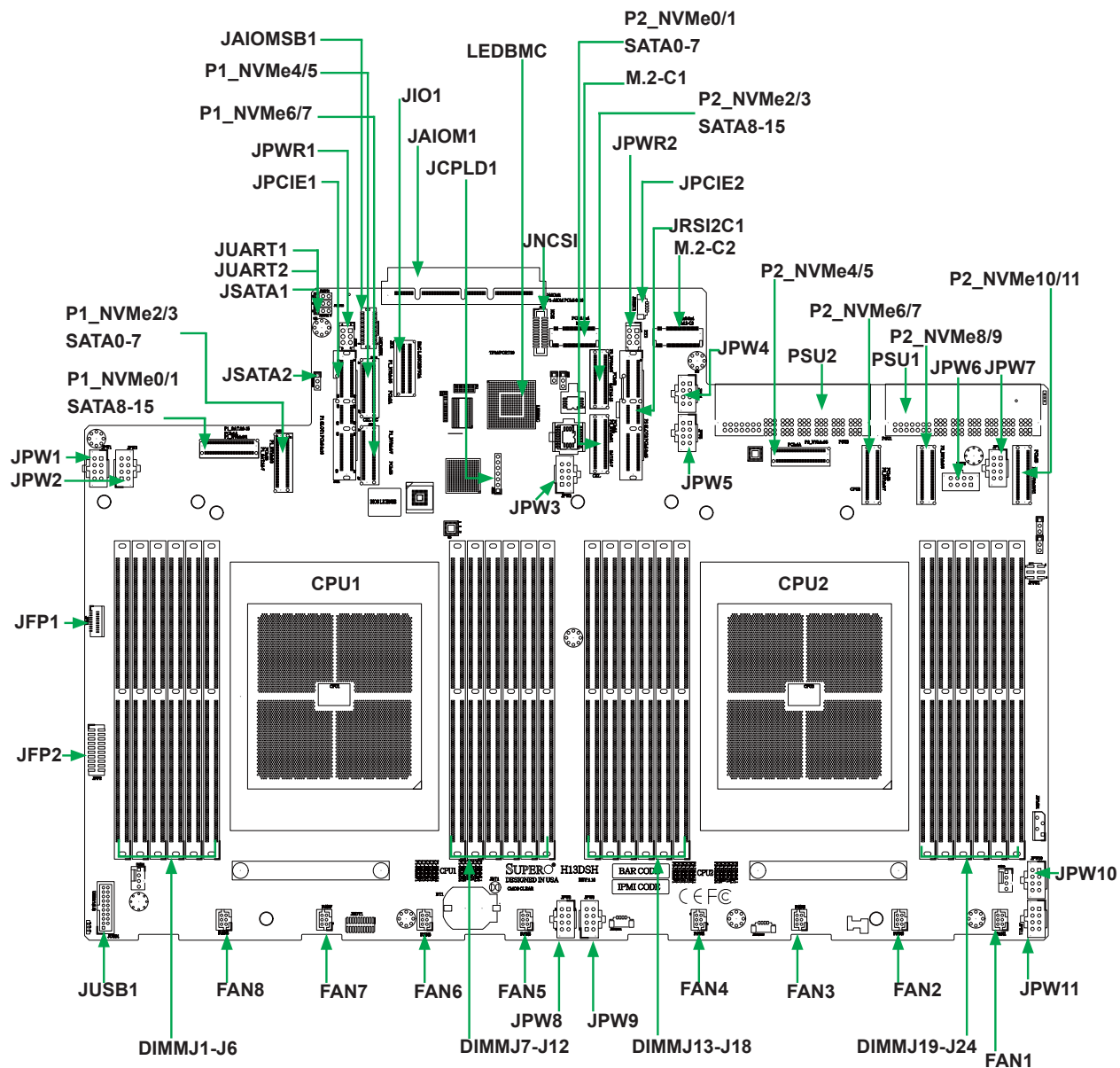

Figure 1-7. Motherboard Layout Revision 1.10/2.0

## Quick Reference Table

Jumper	Description	Default Setting
JBT1	CMOS Clear	Open (Normal)
JSATA1	Hybrid MCIO Select	Open (NVMe)
JSATA2	Hybrid MCIO Select	Open (NVMe)

LED	Description	Status
LED_PWR	Power LED	Solid Green: Power On
LEDBMC	BMC Heartbeat LED	Green: Blinking (BMC Normal) Green: Fast Blinking (BMC Initializing)

Connector	Description
JNCSI1	NCSI Connector
JAIOM1*	Supermicro® Advanced I/O Module (AIOM) Slot
JAIOM1SB1	AIOM1 Sideband Signals Header
JIO1	Front IPMI and Onboard VGA / USB / NIC Module Connector
JPWR2*	24-pin ATX Main Power Connector
JPW1~JPW5	12V 8-Pin GPU / BPN / AOC Power Connector
JPW6~JPW11*	12V 8-Pin GPU / BPN / AOC Power Connector
JFP1	Front Panel Connector
JFP2*	Front VGA Header
JSATA1	SATA0~15
JSATA2	SATA16~31
PSU1/2	Serverboard Main Power Supply Connector
BT1	Onboard Battery
M.2-C1 / M.2-C2	M/2 PCIe Interfaces (NVMe only)
P1_NVMe0/1 PCIe1A	Processor 1 NVMe Ports 0/1 / P1_SATA 8~15
P1_NVMe2/3 PCIe1B	Processor 1 NVMe Ports 2/3 / P1_SATA 0~7
P1_NVMe4/5 PCIe2A	Processor 1 NVMe Ports 4/5
P1_NVMe6/7 PCIe2B	Processor 1 NVMe Ports 6/7
P2_NVMe0/1 PCIe3A	Processor 2 NVMe Ports 0/1 / P2_SATA 0~7
P2_NVMe2/3 PCIe3B	Processor 2 NVMe Ports 2/3 / P2_SATA 8~15
P2_NVMe4/5 PCIe4A	Processor 2 NVMe Ports 4/5
P2_NVMe6/7 PCIe4B	Processor 2 NVMe Ports 6/7
P2_NVMe8/9 PCIe5A	Processor 2 NVMe Ports 8/9
P2_NVMe10/11 PCIe5B	Processor 2 NVMe Ports 10/11
FAN1~8	System Cooling Fan Headers
JPCIE1 (CPU1 Slot1)	PCIe 5.0 x16 Slot Supported by CPU1
JPCIE2 (CPU2 Slot2)	PCIe 5.0 x16 Slot Supported by CPU2
JIPMB1	4-Pin External BMC I <sup>2</sup> C Header

See Notes on the next page.

Notes:

- "\*" represents additional connector update on motherboard layout revision 1.10/2.0.
- Components not documented are for internal testing only.
- See Chapter 4 for detailed information on jumpers, I/O ports, and JF1 front panel connections.
- Use only the correct type of onboard CMOS battery as specified by the manufacturer. To avoid possible explosion, do not install the onboard battery upside down."

# Chapter 2

## Server Installation

### 2.1 Overview

This chapter provides advice and instructions for mounting your system in a server rack. If your system is not already fully integrated with processors, system memory, etc., refer to [Chapter 3](#) for details on installing those specific components.

**Caution:** Electrostatic Discharge (ESD) can damage electronic components. To prevent such damage to PCBs (printed circuit boards), it is important to use a grounded wrist strap, handle all PCBs by their edges and keep them in anti-static bags when not in use.

### 2.2 Unpacking the System

Inspect the box in which the system was shipped, and note if it was damaged in any way. If any equipment appears damaged, file a damage claim with the carrier who delivered it.

Decide on a suitable location for the rack unit that will hold the server. It should be situated in a clean, dust-free area that is well ventilated. Avoid areas where heat, electrical noise, and electromagnetic fields are generated. It will also require a grounded AC power outlet nearby. Be sure to read the precautions and considerations noted or in [Appendix A](#).

### 2.3 Preparing for Setup

The box in which the system was shipped should include the rackmount hardware needed to install it into the rack. Please read this section in its entirety before you begin the installation.

#### Choosing a Setup Location

- The system should be situated in a clean, dust-free area that is well ventilated. Avoid areas where heat, electrical noise, and electromagnetic fields are generated.
- Leave enough clearance in front of the rack so that you can open the front door completely (approximately 25 inches) and approximately 30 inches of clearance in the back of the rack to allow sufficient space for airflow and access when servicing.
- This product should be installed only in a Restricted Access Location (dedicated equipment rooms, service closets, etc.).

- This product is not suitable for use with visual display workplace devices according to §2 of the German Ordinance for Work with Visual Display Units.

## Rack Precautions

- Ensure that the leveling jacks on the bottom of the rack are extended to the floor so that the full weight of the rack rests on them.
- In single rack installations, stabilizers should be attached to the rack. In multiple rack installations, the racks should be coupled together.
- Always make sure the rack is stable before extending a server or other component from the rack.
- You should extend only one server or component at a time - extending two or more simultaneously may cause the rack to become unstable.

## Server Precautions

- Review the electrical and general safety precautions in [Appendix A](#).
- Determine the placement of each component in the rack *before* you install the rails.
- Install the heaviest server components at the bottom of the rack first and then work your way up.
- Use a regulating uninterruptible power supply (UPS) to protect the server from power surges and voltage spikes and to keep your system operating in case of a power failure.
- Allow any drives and power supply modules to cool before touching them.
- When not servicing, always keep the front door of the rack and all covers/panels on the servers closed to maintain proper cooling.

## Rack Mounting Considerations

### *Ambient Operating Temperature*

If installed in a closed or multi-unit rack assembly, the ambient operating temperature of the rack environment may be greater than the room's ambient temperature. Therefore, consideration should be given to installing the equipment in an environment compatible with the manufacturer's maximum rated ambient temperature (TMRA).

### ***Airflow***

Equipment should be mounted into a rack so that the amount of airflow required for safe operation is not compromised.

### ***Mechanical Loading***

Equipment should be mounted into a rack so that a hazardous condition does not arise due to uneven mechanical loading.

### ***Circuit Overloading***

Consideration should be given to the connection of the equipment to the power supply circuitry and the effect that any possible overloading of circuits might have on overcurrent protection and power supply wiring. Appropriate consideration of equipment nameplate ratings should be used when addressing this concern.

### ***Reliable Ground***

A reliable ground must be maintained at all times. To ensure this, the rack itself should be grounded. Particular attention should be given to power supply connections other than the direct connections to the branch circuit (i.e. the use of power strips, etc.).



To prevent bodily injury when mounting or servicing this unit in a rack, you must take special precautions to ensure that the system remains stable. The following guidelines are provided to ensure your safety:

- This unit should be mounted at the bottom of the rack if it is the only unit in the rack.
- When mounting this unit in a partially filled rack, load the rack from the bottom to the top with the heaviest component at the bottom of the rack.
- If the rack is provided with stabilizing devices, install the stabilizers before mounting or servicing the unit in the rack.
- Slide rail mounted equipment is not to be used as a shelf or a workspace.



Slide rail mounted equipment is not to be used as a shelf or a workspace.



**Warning:** Do not pick up the server with the front handles. They are designed to pull the system from a rack only.

## 2.4 Installing the Rails

This section provides information on installing the chassis into a rack unit with the rails provided. There are a variety of rack units on the market, which may mean that the assembly procedure will differ slightly from the instructions provided. You should also refer to the installation instructions that came with the rack unit you are using. **Note:** This rail will fit a rack between 26.8" and 36.4" deep.

### Identifying the Rails

The chassis package includes two rail assemblies (MCP-290-11903-0N). Each assembly consists of three sections: An inner rail that secures directly to the chassis, an outer rail that secures to the rack, and a middle rail which extends from the outer rail. These assemblies are specifically designed for the left and right side of the chassis and labeled.

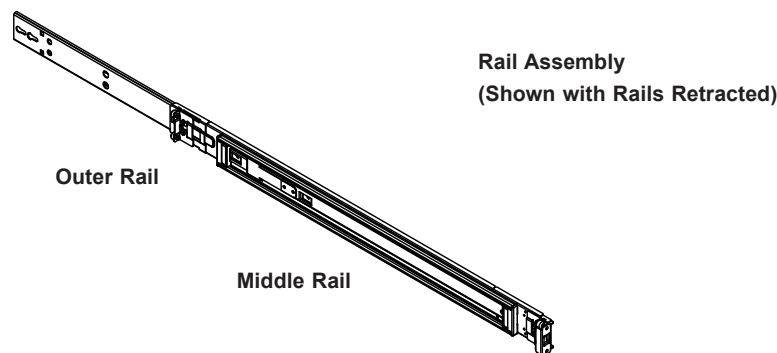

**Figure 2-1. Identifying the Outer Rail, Middle Rail and Inner Rail**  
(Left Rail Assembly Shown)

**Note:** Both front chassis rails and the rack rails have a locking tab, which serves two functions. First, it locks the chassis into place when installed and pushed fully into the rack (its normal operating position). In addition, these tabs lock the chassis in place when fully extended from the rack. This prevents the chassis from coming completely out of the rack when pulled out for servicing.

## Releasing the Inner Rail

Each inner rail has a locking latch. This latch prevents the chassis from coming completely out of the rack when the chassis is pulled out for servicing.

To mount the rail onto the chassis, first release the inner rail from the outer rails.

1. Pull the inner rail out of the outer rail until it is fully extended as illustrated below.
2. Press the locking tab down to release the inner rail.
3. Pull the inner rail all the way out.

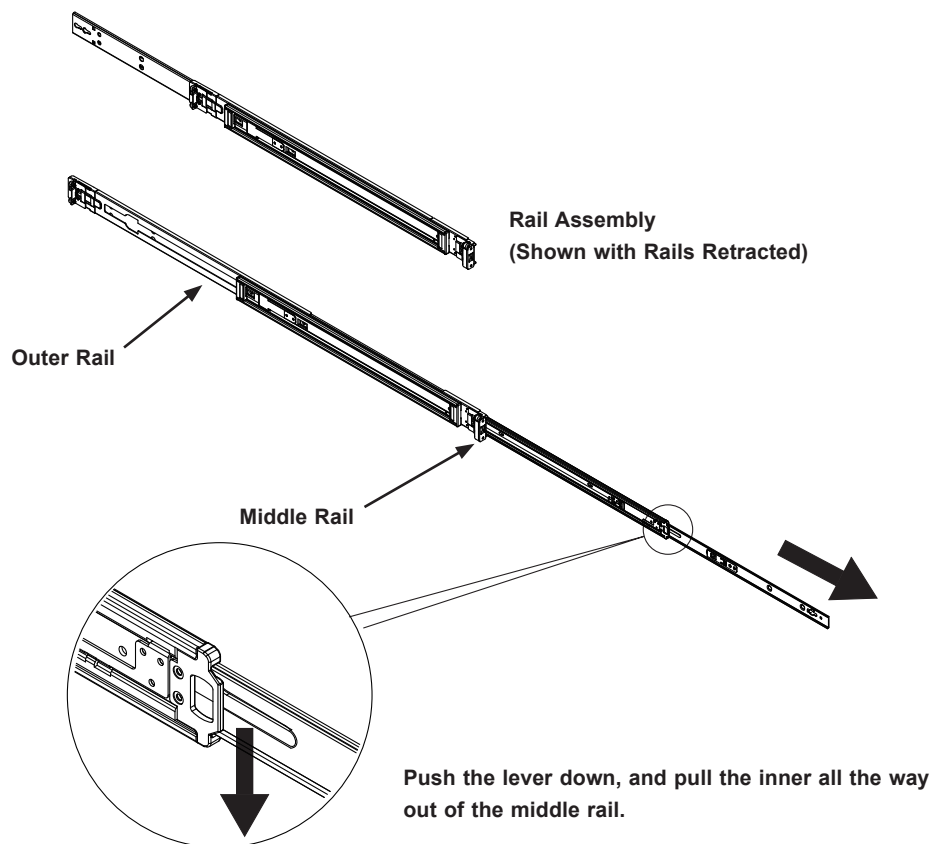

**Figure 2-2. Extending and Releasing the Inner Rail**

## Installing the Inner Rails

Begin the rack mounting procedure by installing the inner rails to the chassis.

1. Identify the left and right inner rails. They are labeled.
2. Place the inner rail firmly against the side of the chassis, aligning the hooks on the side of the chassis with the holes in the inner rail.
3. Slide the inner rail forward toward the front of the chassis and under the hooks until the quick release bracket snaps into place, securing the rail to the chassis.
4. Optionally, you can further secure the inner rail to the chassis with a screw.

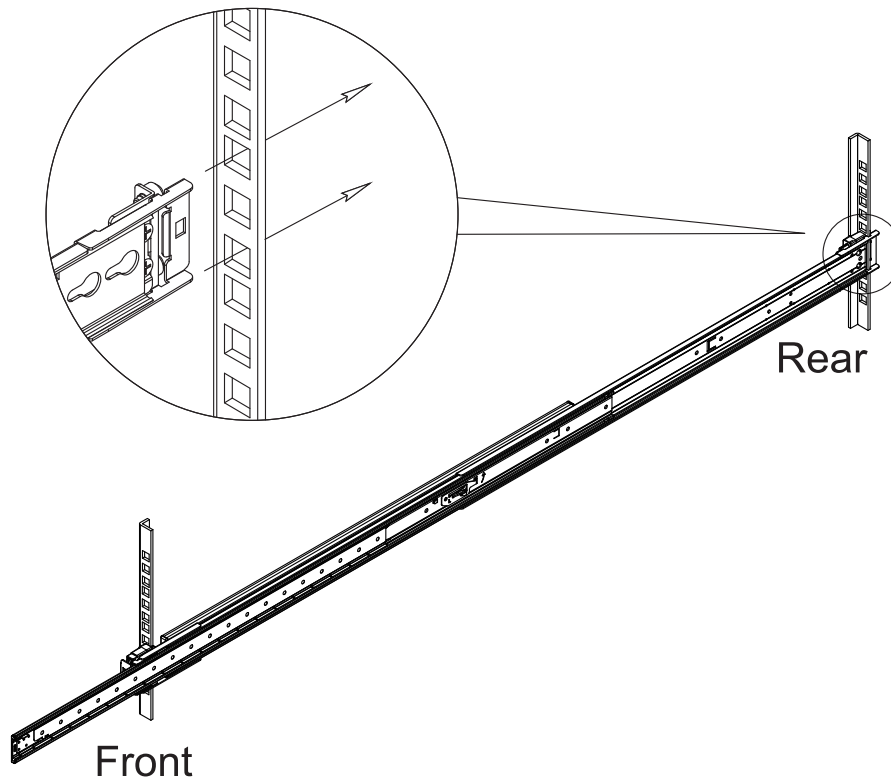

Figure 2-3. Installing the Rails



**Warning:** Do not pick up the chassis with the front handles. They are designed to pull the system from a rack only.

## Installing the Outer Rails onto the Rack

1. Press upward on the locking tab at the rear end of the middle rail.
2. Push the middle rail back into the outer rail.
3. Hang the hooks on the front of the outer rail onto the square holes on the front of the rack. If desired, use screws to secure the outer rails to the rack.
4. Pull out the rear of the outer rail, adjusting the length until it just fits within the posts of the rack.
5. Hang the hooks of the rear section of the outer rail onto the square holes on the rear of the rack. Take care that the proper holes are used so the rails are level. If desired, use screws to secure the rear of the outer rail to the rear of the rack.

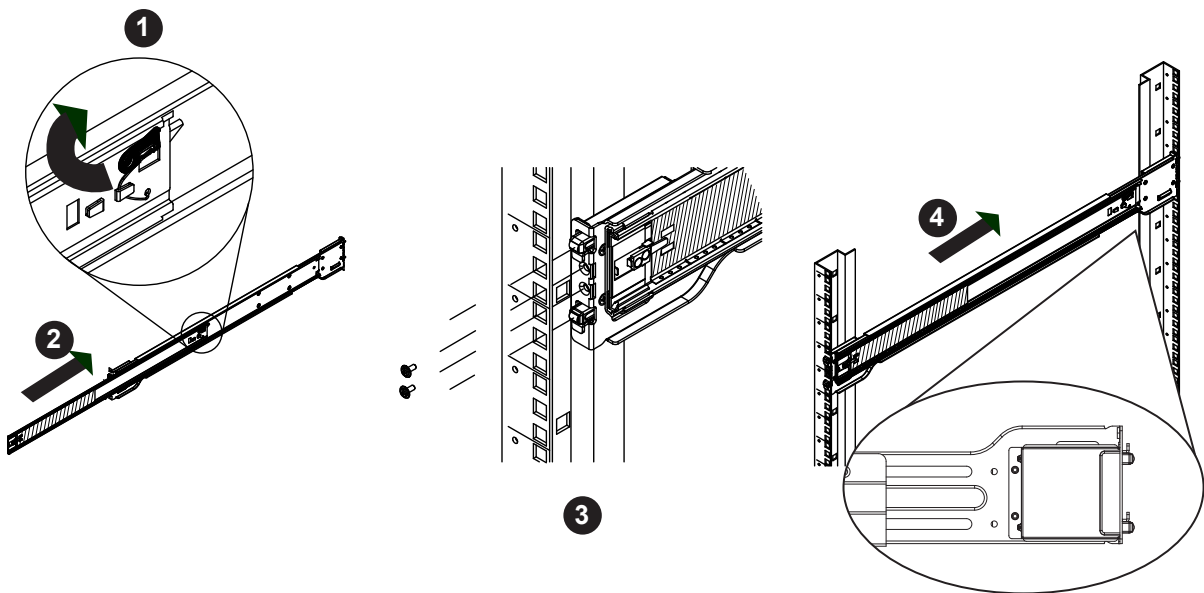

Figure 2-4. Extending and Mounting the Outer Rails

## 2.5 Installing the Chassis into a Rack

Once rails are attached to the chassis and the rack, you can install the chassis.

1. Pull the middle rail out of the front of the outer rail and make sure that the ball bearing shuttle is locked at the front of the middle rail.
2. Align the rear of the chassis rails with the middle rails and then push evenly on both sides of the chassis until it clicks into the fully extended position.
3. Depress the locking tabs on both sides of the chassis and push the it fully into the rack. The locking tabs should "click".
4. Optional screws may be used to hold the front of the chassis to the rack.

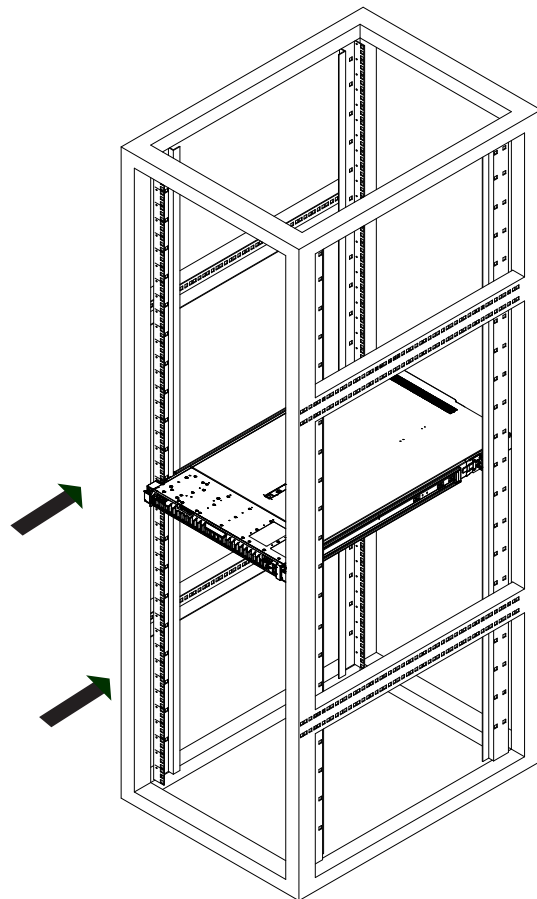

Figure 2-5. Installing the chassis into the Rack

### Notes:

- Keep the ball bearing shuttle locked at the front of the middle rail during installation.
- Figure is for illustrative purposes only. Always install a chassis to the bottom of a rack first.

## Removing the Chassis from the Rack

**Caution!** It is dangerous for a single person to off-load the heavy chassis from the rack without assistance. Be sure to have sufficient assistance supporting the chassis when removing it from the rack. Use a lift.

1. Pull the chassis forward out the front of the rack until it stops.
2. Press the release latches on each of the inner rails downward simultaneously and continue to pull the chassis forward and out of the rack.

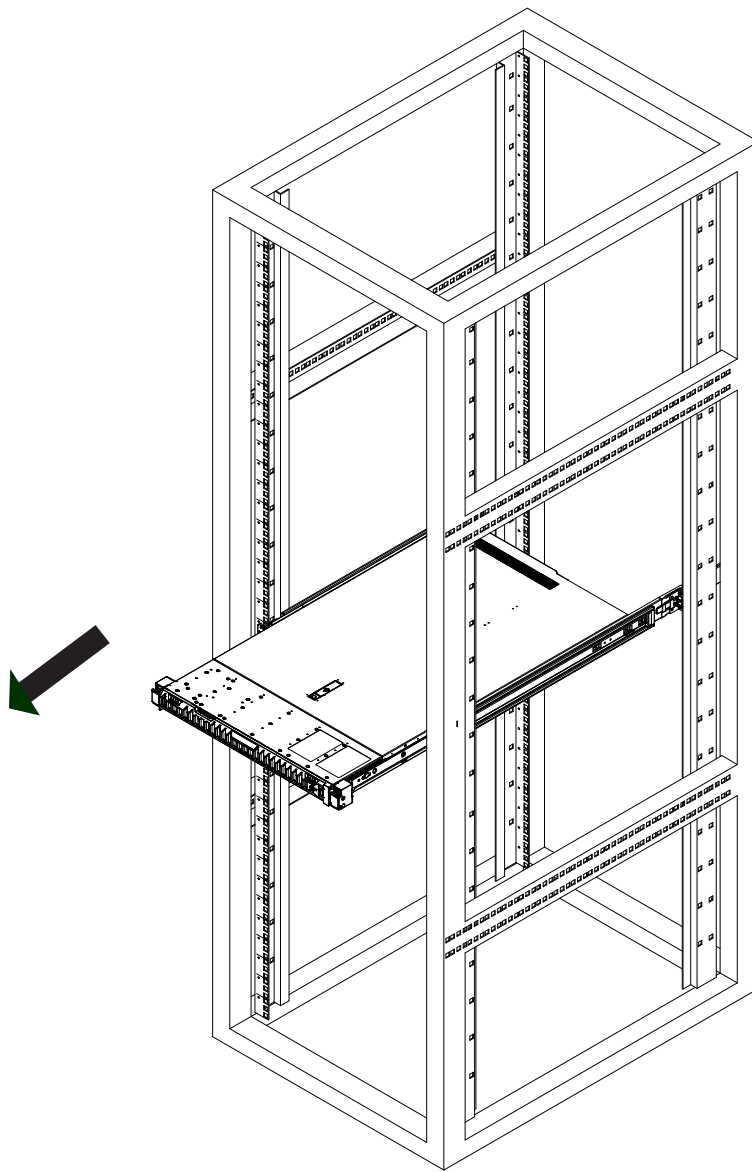

Figure 2-6. Removing the Chassis From the Rack

## Chapter 3

# Maintenance and Component Installation

This chapter provides instructions on installing and replacing main system components. To prevent compatibility issues, only use components that match the specifications and/or part numbers given.

Installation or replacement of most components requires that power first be removed from the system. Please follow the procedures given in each section.

### 3.1 Removing Power

Use the following procedure to ensure that power has been removed from the system. This step is necessary when removing or installing non-hot-swap components or when replacing a non-redundant power supply.

1. Use the operating system to power down the system.
2. After the system has completely shut-down, disconnect the AC power cord(s) from the power strip or outlet. (If your system has more than one power supply, remove the AC power cords from all power supply modules.)
3. Disconnect the power cord(s) from the power supply module(s).

## 3.2 Accessing the System

The CSE-HS119-R1K24P2-A chassis features a removable top cover, which allows easy access to the inside of the chassis.

### *Removing the Top Cover*

1. Press the release button and slide the cover toward the rear.
2. Lift the top cover up.

Check that all ventilation openings on the top cover and the top of the chassis are clear and unobstructed.

**Caution:** Except for short periods of time, do not operate the server without the cover in place. The chassis cover must be in place to allow for proper airflow and to prevent overheating.

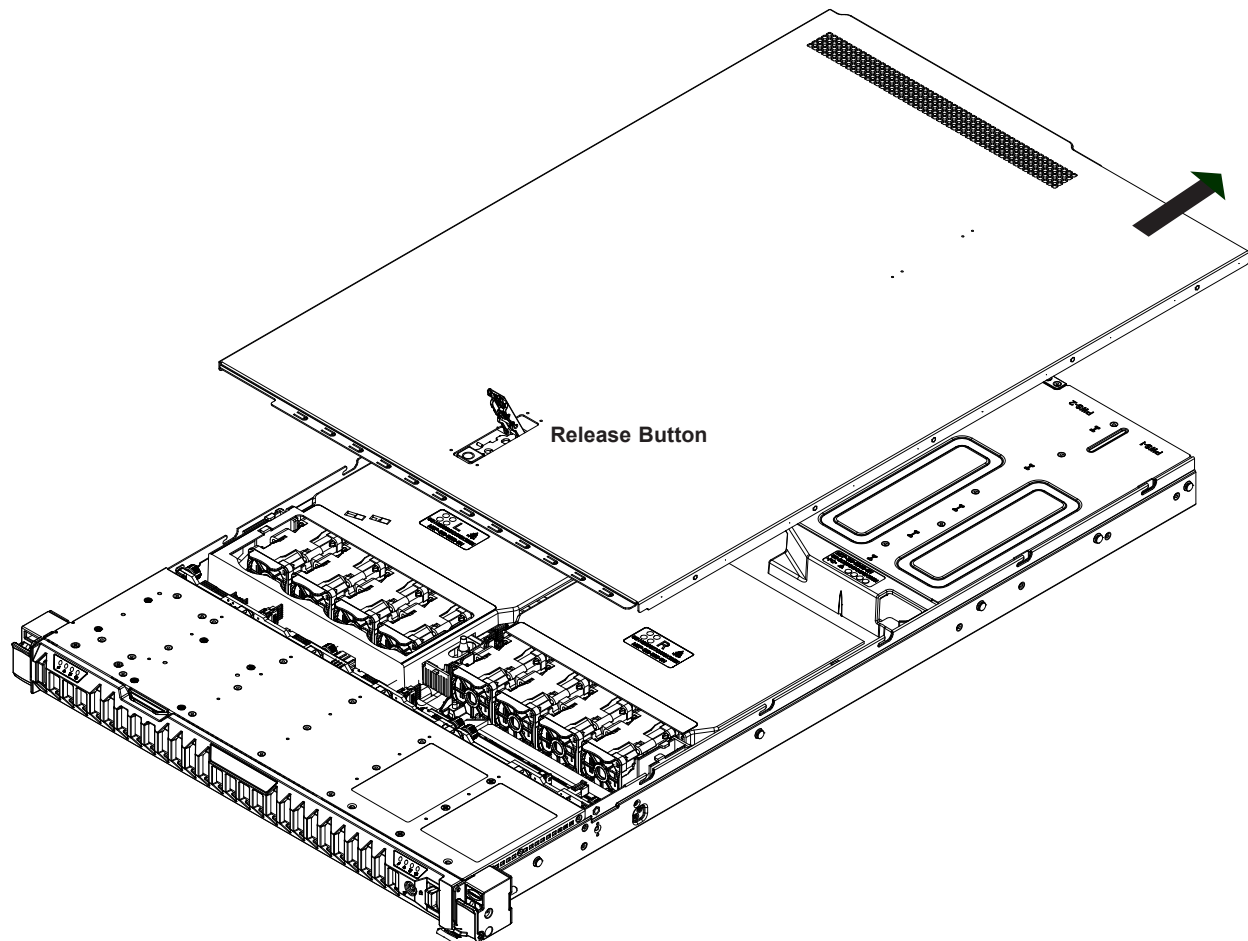

Figure 3-1. Removing the Chassis Cover

### 3.3 Processor and Heatsink Installation

**Warning:** When handling the processor package, avoid placing direct pressure on the label area of the fan.

**Important:**

- For the Processor/Heatsink installation you need to use a T20 screwdriver when opening/closing the CPU socket.
- Always connect the power cord last, and always remove it before adding, removing or changing any hardware components. Make sure that you install the processor into the CPU socket before you install the CPU heatsink.
- If you buy a CPU separately, make sure that you use an AMD-certified multi-directional heatsink only.
- Make sure to install the motherboard into the chassis before you install the CPU heatsink.
- When receiving a motherboard without a processor pre-installed, make sure that the plastic CPU socket cap is in place and none of the socket pins are bent; otherwise, contact your retailer immediately.
- When installing the processor and heatsink, ensure a torque driver set to the correct force is used for each screw.
- Refer to the Supermicro website for updates on CPU support.

***Installing the Processor and Heatsink***

1. Unscrew the screw #1 holding down the force frame.

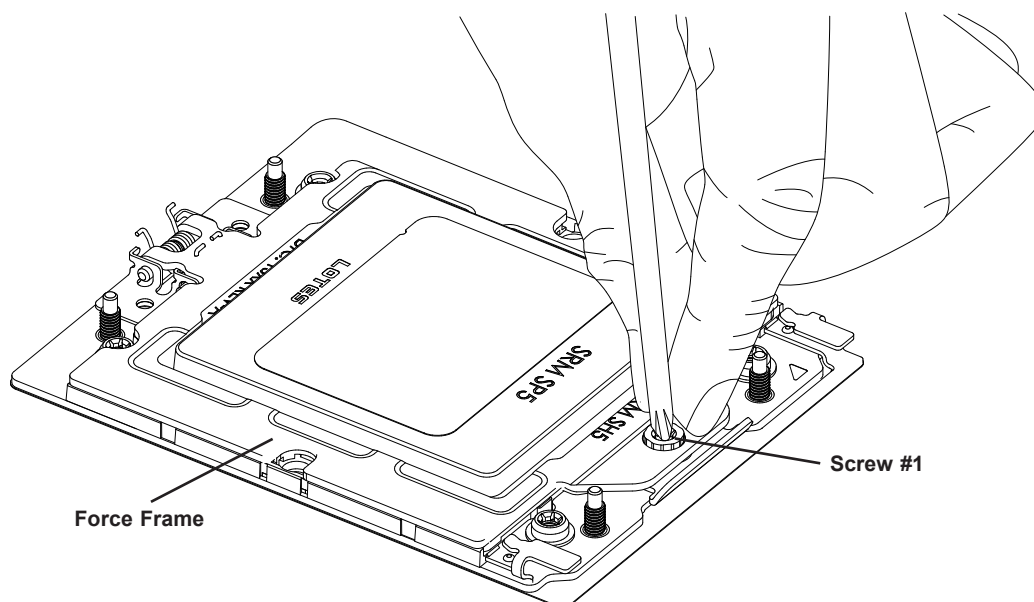

2. The spring-loaded force frame will rise up after the screw securing it (#1) is removed. Gently allow it to lift up to its stopping position.

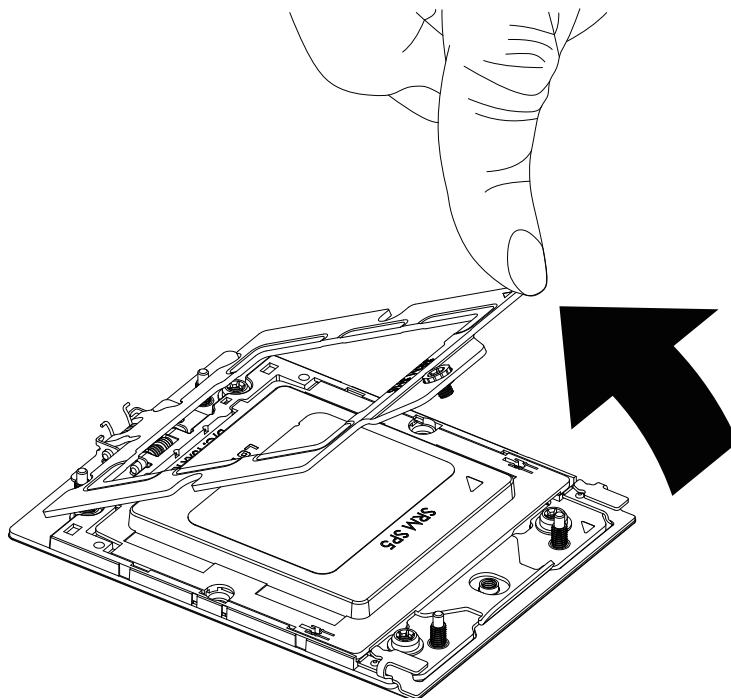

3. Lift the rail frame up by gripping the lift tabs near the front end of the rail frame. While keeping a secure grip of the rail frame, lift it to a position so you can do the next step of removing the external cap.

**Note:** The rail frame is spring loaded, so keep a secure grip on it as you lift it so it does not snap up.

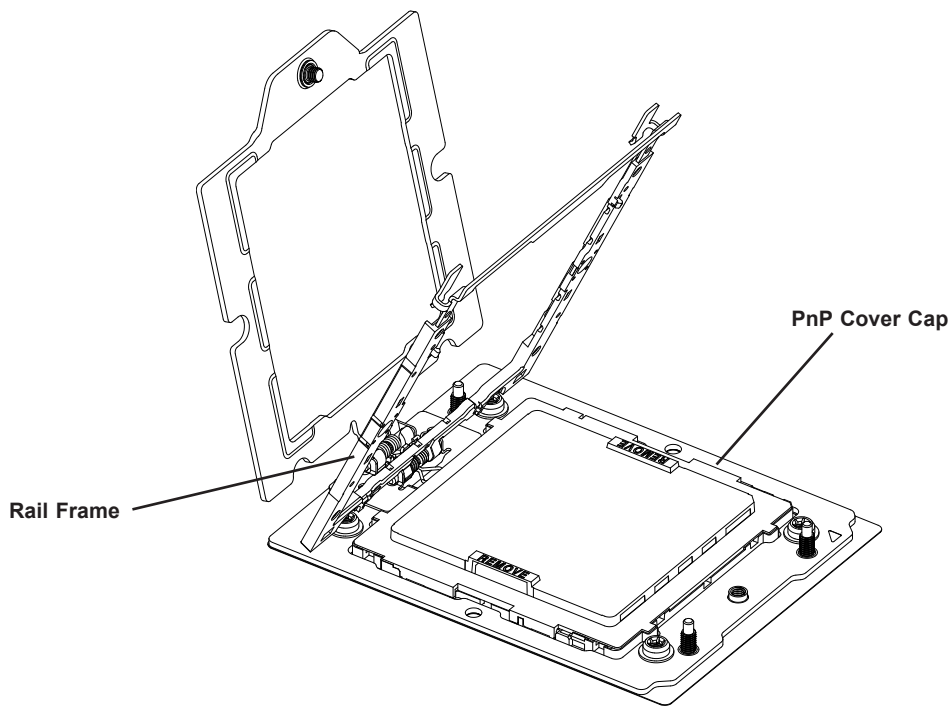

4. Remove the external cap from the rail frame by pulling it upwards through the rail guides on the rail frame.

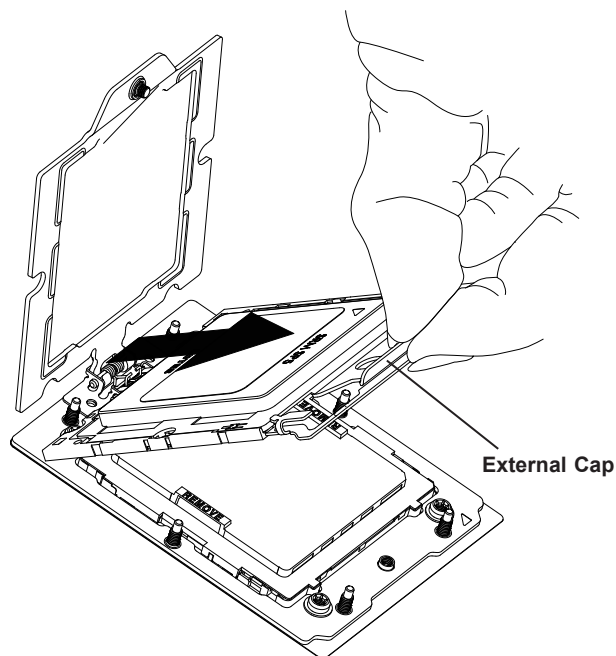

5. The CPU package is shipped from the factory with the carrier frame pre-assembled. Grip the handle of the carrier frame/CPU package assembly from its shipping tray, and while gripping the handle, align the flanges of the carrier frame onto the rails of the rail frame so its pins will be at the bottom when the rail frame is lowered later.
6. Slide the carrier frame/CPU package downwards to the bottom of the rail frame. Ensure the flanges are secure on the rails as you lower it downwards.

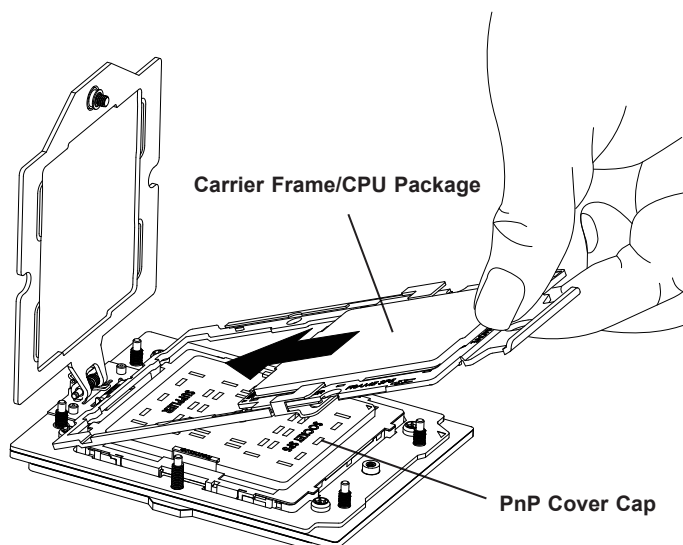

**Note:** You can only install the CPU inside the socket in one direction with the handle at the top. Make sure that it is properly inserted into the CPU socket before closing the rail frame plate. If it doesn't close properly, do not force it as it may damage your CPU. Instead, open the rail frame plate again, and double-check that the CPU is aligned properly.

7. Lift up the rail frame till it securely rests in upright position. Then remove the PnP cover cap from the CPU socket below. Grip the two lift tabs marked "Remove" at the middle of the cap and pull vertically upwards to remove the PnP cover cap.

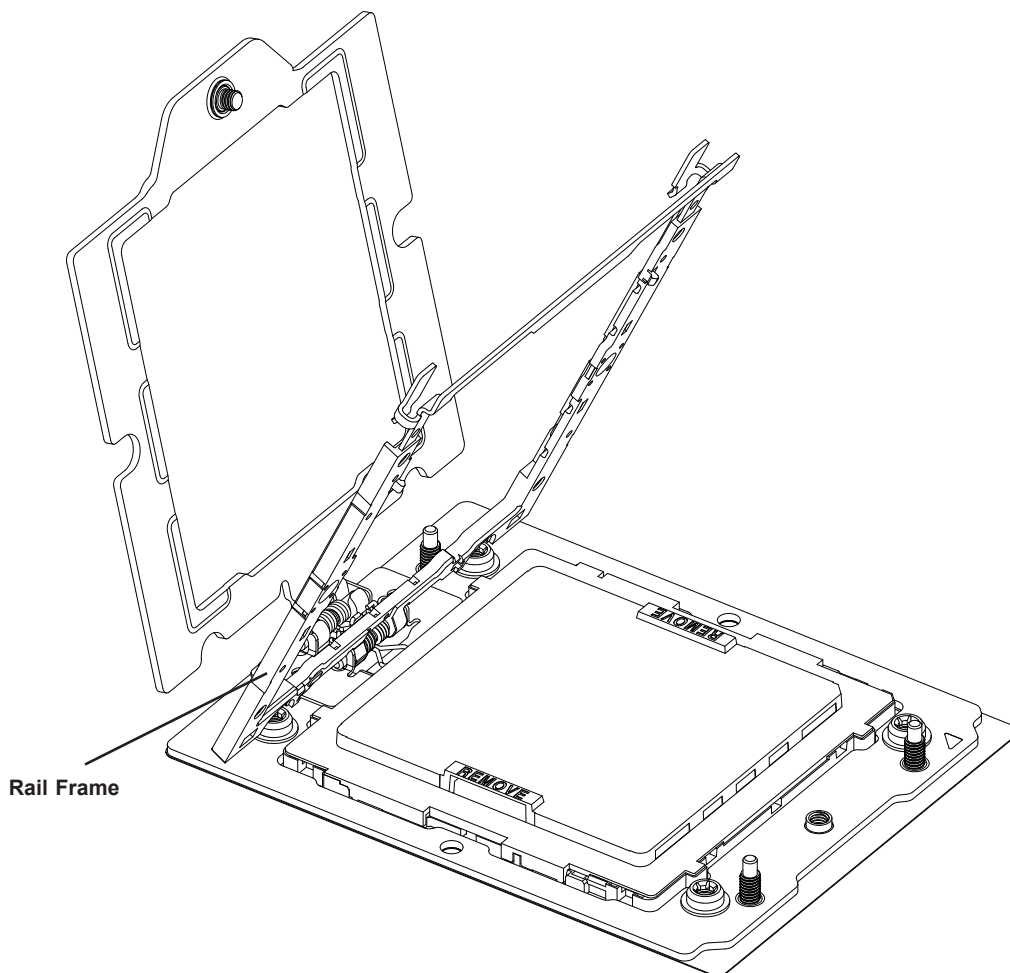

**Warning!** The exposed socket contacts are extremely vulnerable and can be damaged easily. Do not touch or drop objects onto the contacts and be careful removing the PnP cover cap and when placing the rail frame over the socket.

8. Gently lower the rail frame down onto the socket until the latches on the rail frame engage with the socket housing and it rests in place. **DO NOT** force it into place!

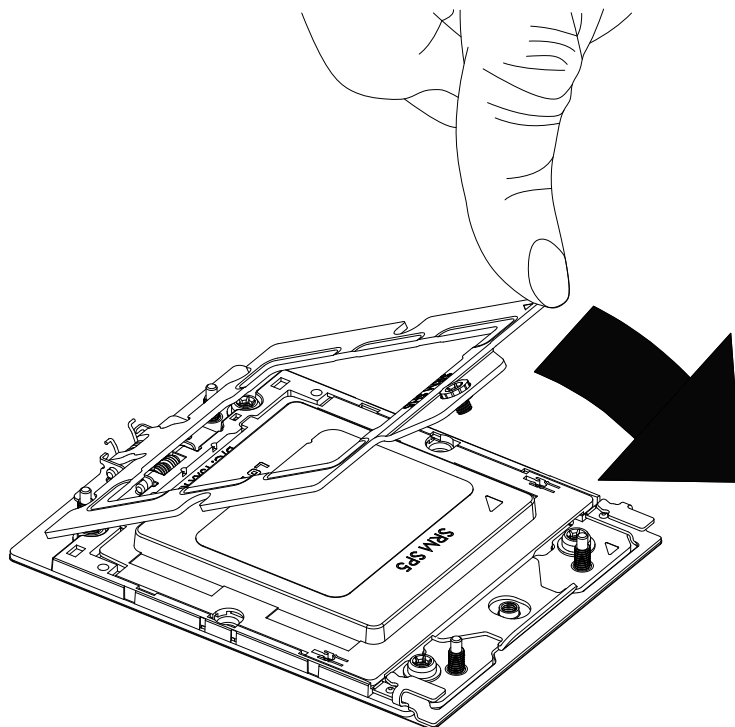

9. Note that the force frame is spring loaded and has to be held in place before it is secured. **Use a torque screwdriver, set it at 12.5~15.0 kgfcm (10.85~13.01 lbf-in) with a Torx T20 screw head bit, to prevent damage to the CPU.**

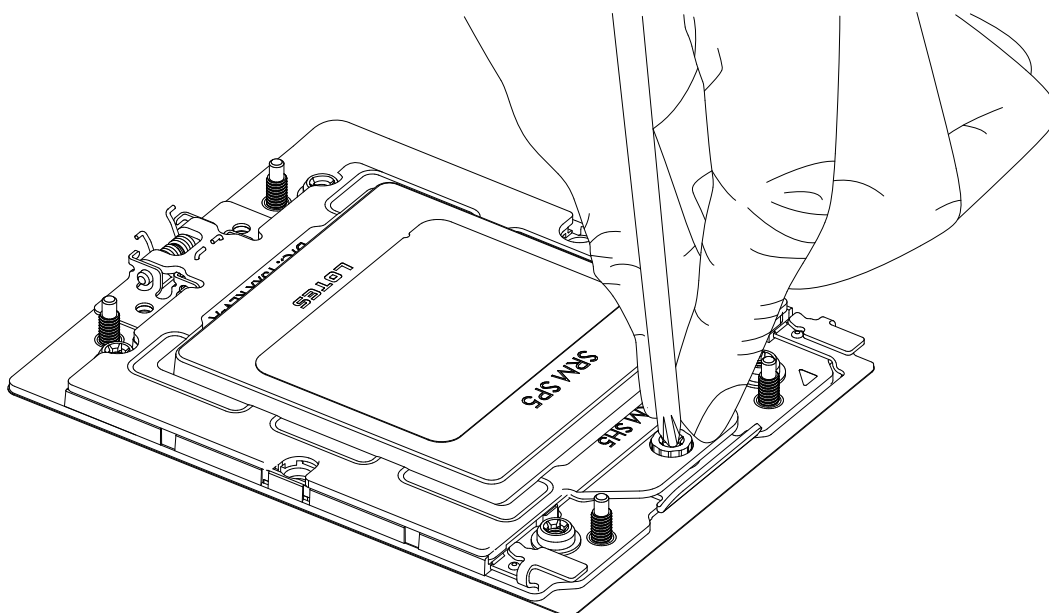

10. Place and re-screw the screw to the way you removed them. When finished, the force frame will be secure over both the rail frame and CPU package.

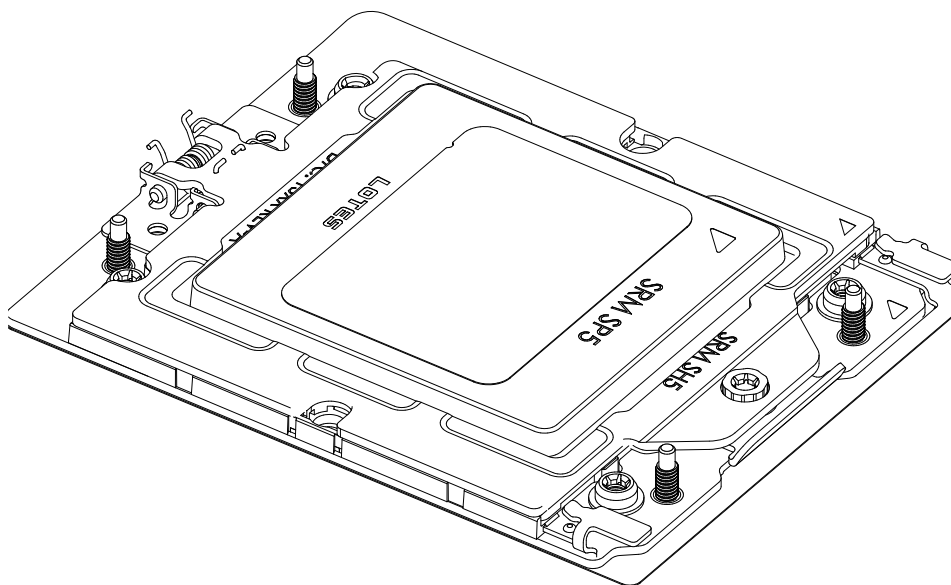

11. After the force frame is secured and the CPU package is in place, now you must install the heatsink to the frame. Lower the heatsink down till it rests securely over the six screw holes on CPU package on the socket frame.

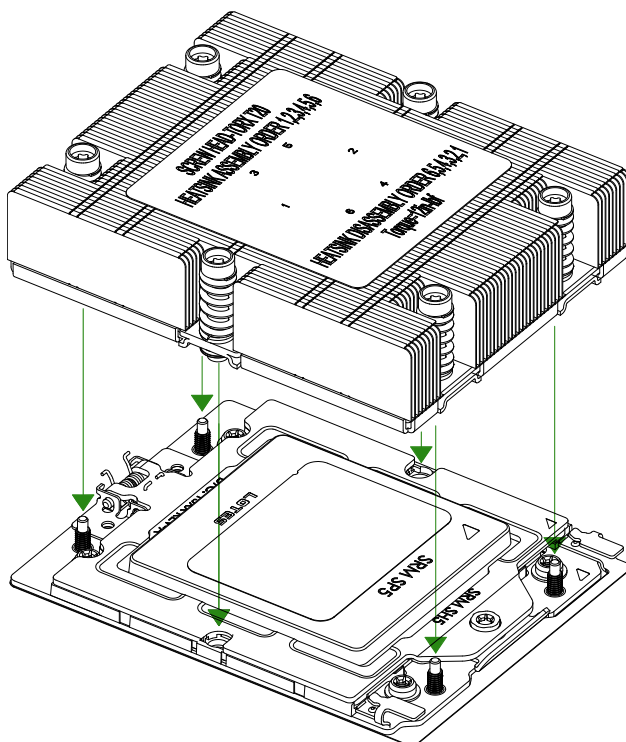

- Using a diagonal pattern, tighten the six screws down on the heatsink in a clockwise fashion till it is secure. Use a torque screwdriver, set it at 12.5-15.0 kgf-cm (10.85-13.01 lbf-in) with a Torx T20 screw head bit, to prevent damage to CPU socket/heatsink. The heatsink will now be secured and you have finished installing the processor and heatsink onto the motherboard. Repeat this procedure for any remaining CPU sockets on the motherboard. Remove the external cap from the rail frame by pulling it upwards through the rail guides on the rail frame.

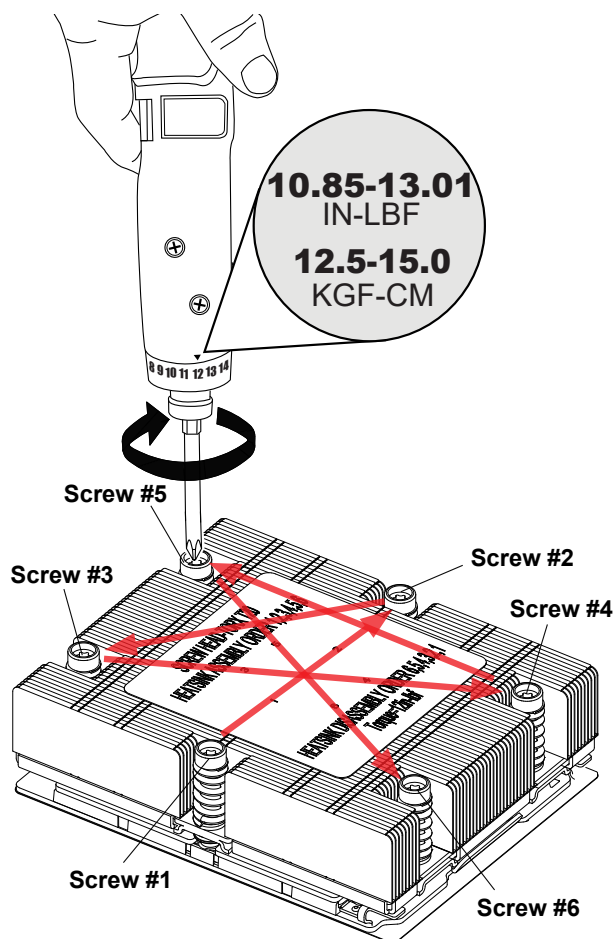

### **Un-installing the Processor and Heatsink**

1. Remove the heatsink attached to the top of the CPU package by reversing the installation procedure.
2. Clean the thermal grease left by the heatsink on the CPU package lid to limit the risk of it contaminating the CPU package land pads or contacts in the socket housing.
3. Unscrewing the plate and lift the force frame to the vertical position.
4. Lift the rail frame using the lift tabs near the front end of the rail frame. Note that the rail frame is spring loaded, so be careful lifting it up into a vertical position.
5. Grip the handle of the carrier frame and pull upwards to extract it from the rail frame. Return the carrier frame/CPU package to its original shipping container.
6. Grip the handle on the external cap and return it to the rail frame sliding it downwards till it rests in the frame.
7. Gripping the rail frame, rotate it downwards till it rests above and locks over the socket housing in its horizontal position.
8. Push and rotate down the force frame till it is over the external cap and rail frame into a horizontal position.
9. While holding down the force frame, secure it back to the socket frame by securing screw #1 in place.

## 3.4 Memory Installation

**Note:** Check the Supermicro website for recommended memory modules.

**Important:** Exercise extreme care when installing or removing memory modules to prevent any possible damage.

### Memory Support

The H13DSH supports up to 6 TB of ECC DDR5 4800 MT/s speed with AMD EPYC™ 9004 series processors installed; 9 TB of ECC DDR5 6000 MT/s speed with AMD EPYC™ 9005 series processors installed (Motherboard revision 2.0 or above is required), RDIMM/3DS memory in 24 slots. Refer to the table below for additional memory information.

**Note:** Check the Supermicro website for possible updates to memory support.

DIMM Population Guide													
Type		Channel											
		F1	E1	D1	C1	B1	A1	G1	H1	I1	J1	K1	L1
2 CPUs and 2 DIMMs	CPU1						V						
	CPU2						V						
2 CPUs and 4 DIMMs	CPU1						V	V					
	CPU2						V	V					
2 CPUs and 8 DIMMs	CPU1				V		V	V		V			
	CPU2				V		V	V		V			
2 CPUs and 12 DIMMs	CPU1				V	V	V	V	V	V			
	CPU2				V	V	V	V	V	V			
2 CPUs and 16 DIMMs	CPU1		V		V	V	V	V	V	V		V	
	CPU2		V		V	V	V	V	V	V		V	
2 CPUs and 20 DIMMs	CPU1		V	V	V	V	V	V	V	V	V	V	
	CPU2		V	V	V	V	V	V	V	V	V	V	
2 CPUs and 24 DIMMs	CPU1	V	V	V	V	V	V	V	V	V	V	V	V
	CPU2	V	V	V	V	V	V	V	V	V	V	V	V

**Note:** Fully populate the motherboard with validated memory modules to achieve the best memory performance.

<b>Populating RDIMM/RDIMM 3DS DDR5 Memory Modules with AMD EPYC™ 9004 Series Processor</b>			
Type	DIMM Population	Maximum Frequency (MT/s)	
	DIMM1	5600 MT/s Grade DIMM	4800 MT/s Grade DIMM
RDIMM	1R	4800	4800
	2R	4800	4800
3DS RDIMM	2S2R (4 ranks)	4800	4800
	2S4R (8 ranks)	4800	4800

<b>Populating RDIMM/RDIMM 3DS DDR5 Memory Modules with AMD EPYC™ 9005 Series Processor (Motherboard revision 2.0 or above is required)</b>				
Type	DIMM Population	Maximum Frequency		
	DIMM1	6400 MT/s Grade DIMM	5600 MT/s Grade DIMM	4800 MT/s Grade DIMM
RDIMM	1R	6000	5600	4800
	2R	6000	5600	4800
3DS RDIMM	2S2R (4 ranks)	6000	5600	4800
	2S2R (8 ranks)	6000	5600	4800

## DIMM Module Population Sequence

There is no specific order or sequence required when installing memory modules. However do keep the following in mind:

- It is recommended that DDR5 DIMM modules of the same type, size and speed should be installed.
- Mixed DIMM speeds can be installed. However, all DIMMs will run at the speed of the slowest DIMM.
- The motherboard will support odd-numbered modules (1 or 3 modules installed). However, to achieve the best memory performance, fully populate the motherboard with validated memory modules.

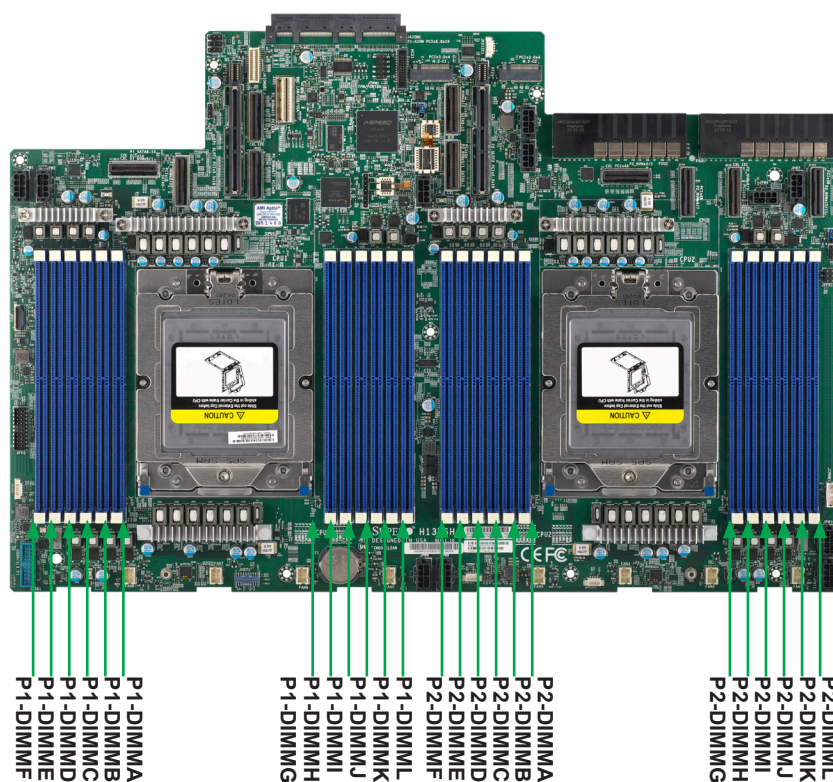
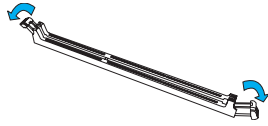

Figure 3-2. DIMM Numbering

## DIMM Installation

1. Insert the desired number of DIMMs into the slots based on the recommended DIMM population tables shown above.
2. Push the release tabs on both ends of the DIMM slot outwards to unlock it.



3. Align the key of the DIMM module with the receptive point on the memory slot.

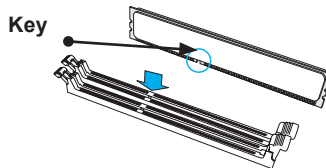

4. Align the notches on both ends of the module with the receptive points on the ends of the slot.

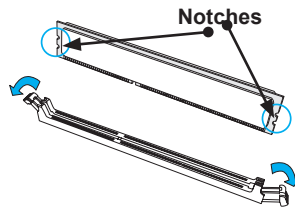

5. Push both ends of the module straight down into the slot until the module snaps into place.

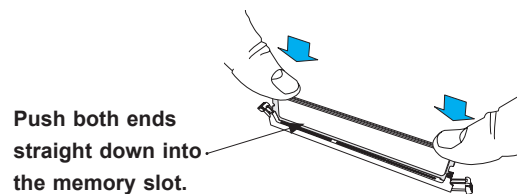

6. Press the release tabs to the lock positions to secure the DIMM module into the slot.

## DIMM Removal

Press both release tabs on the ends of the DIMM module to unlock it. Once the DIMM module is loose, remove it from the memory slot.

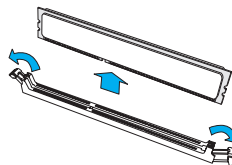

**Warning!** To avoid causing any damage to the DIMM module or the DIMM socket, do not use excessive force when pressing the release tabs on the ends of the DIMM socket. Handle DIMMs with care. Be aware and follow the ESD instructions given at the beginning of this chapter.

## 3.5 Motherboard Battery

The motherboard uses non-volatile memory to retain system information when system power is removed. This memory is powered by a lithium battery residing on the motherboard.

### Battery Removal

*To remove the onboard battery, follow the steps below:*

1. Power off your system and unplug your power cable.
2. Locate the onboard battery as shown below.
3. Using a tool such as a pen or a small screwdriver, push the battery lock outwards to unlock it. Once unlocked, the battery will pop out from the holder.
4. Remove the battery.

### Proper Battery Disposal

Please handle used batteries carefully. Do not damage the battery in any way; a damaged battery may release hazardous materials into the environment. Do not discard a used battery in the garbage or a public landfill. Please comply with the regulations set up by your local hazardous waste management agency to dispose of your used battery properly.

### Battery Installation

1. To install an onboard battery, follow the steps 1 & 2 above and continue below:
2. Identify the battery's polarity. The positive (+) side should be facing up.
3. Insert the battery into the battery holder and push it down until you hear a click to ensure that the battery is securely locked.

**Important:** When replacing a battery, be sure to only replace it with the same type.

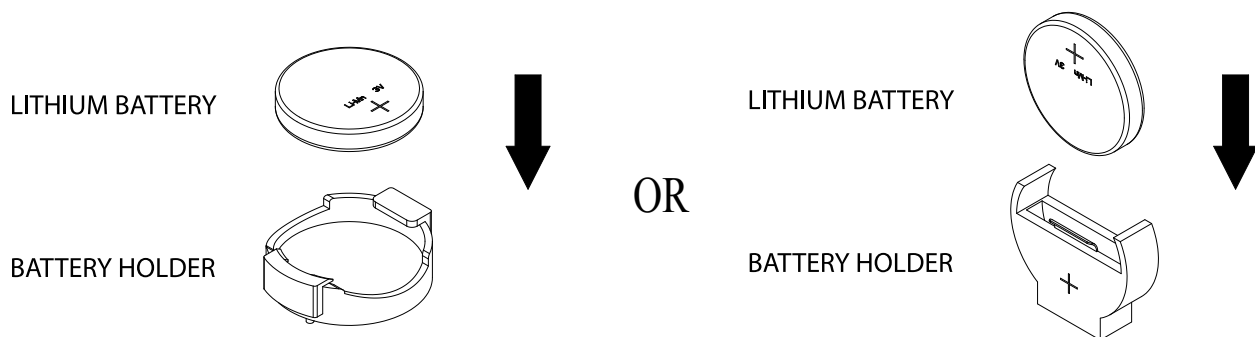

**Figure 3-3. Battery Installation**

## 3.6 Storage Drives

The storage drives are mounted in tool-less drive carriers that simplify their removal from the chassis. These carriers also help promote proper airflow. For compatible storage drives, see the AS -1125HS-TNR\_product page.

### Installing Drives



Figure 3-4. Logical Drive Number

**Note:** The NVMe storage numbering is not sequential in the OS when M.2 NVMe SSDs are installed.

Please refer to the FAQ link <https://www.supermicro.com/support/faqs/faq.cfm?faq=36169>

#### ***Removing a Hot-Swap Drive Carrier from the Chassis***

1. Press the release button on the drive carrier, which will extend the drive carrier handle.
2. Use the drive carrier handle to pull the drive out of the chassis.

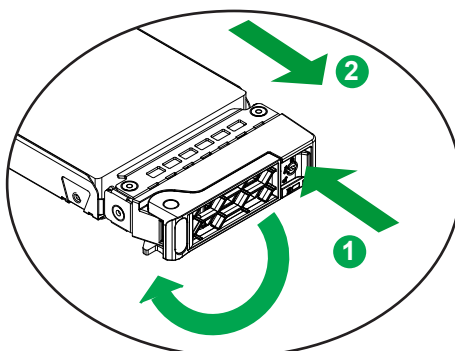
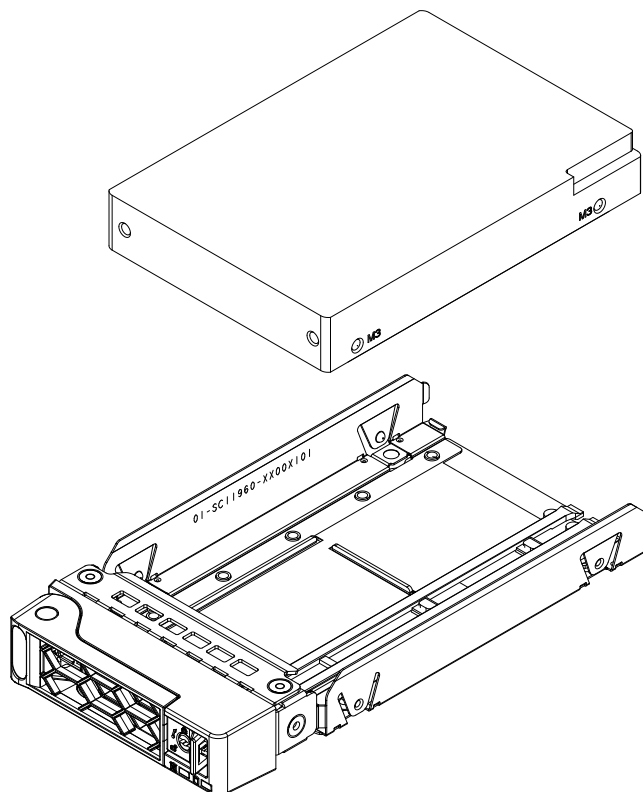

Figure 3-5. Removing a Drive Carrier

### ***Installing a Drive***

1. Insert a drive into the carrier with the PCB side facing down and the connector end toward the rear of the carrier. Place the drive in the carrier so that the screw holes line up.
2. The drive carrier has a tool-less design but you also have the option to secure the drive to the carrier with two M3 screws. These screws are included in the chassis accessory box.



**Figure 3-6. Mounting a Drive in the Carrier**

3. Insert the drive carrier with the disk drive into its bay, keeping the carrier oriented so that the hard drive is on the top of the carrier and the release button is on the right side. When the carrier reaches the rear of the bay, the release handle will retract.
4. Push the handle in until it clicks into its locked position.

## Hot-Swap for NVMe Drives

Supermicro servers support NVMe surprise hot-swap. For even better data security, NVMe *orderly* hot-swap is recommended. NVMe drives can be ejected and replaced remotely using BMC.

### Ejecting a Drive

1. **BMC > Server Health > NVMe SSD**
2. Select Device, Group, and Slot, and click **Eject**. After ejecting, the drive Status LED indicator turns green.
3. Remove the drive.

Note that *Device* and *Group* are categorized by the CPLD design architecture.

A *Slot* is the slot number on which the NVMe drives are mounted. Also, note that only one drive can be ejected at a time.

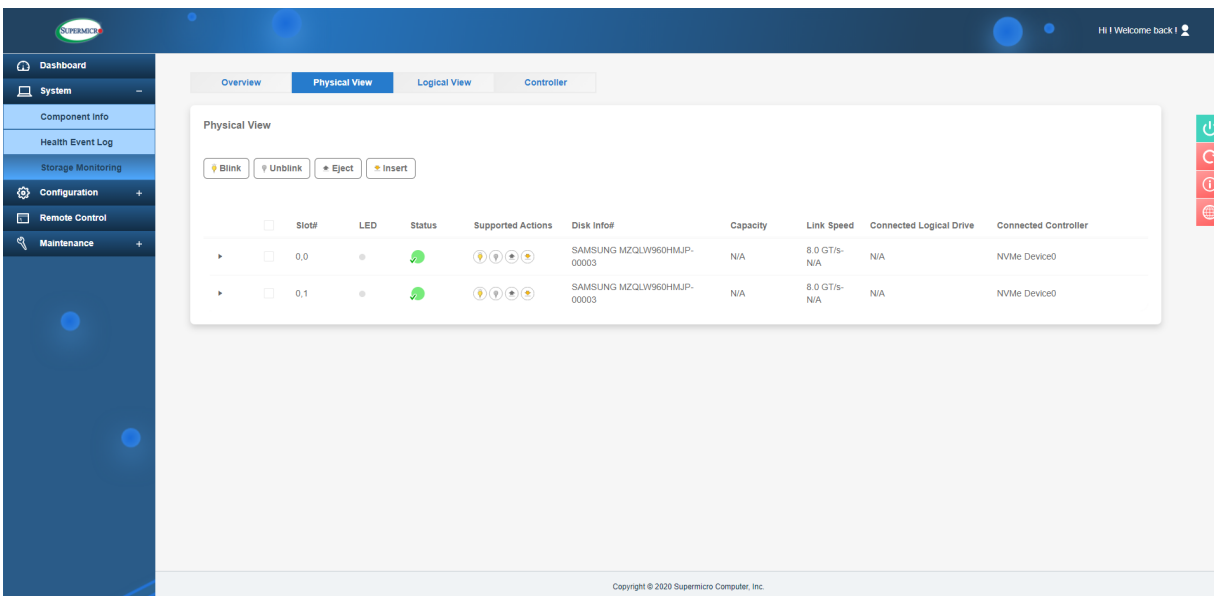

Figure 3-7. BMC Screenshot

### Replacing the Drive

1. Insert the replacement drive.
2. **BMC > System > Storage Monitor > Physical View**
3. Select Device, Group, and slot and click **Insert**. The drive Status LED indicator flashes red, then turns off. The Activity LED turns blue.

## 3.7 System Cooling

### Fans

Eight 4-cm heavy-duty fans provide cooling for the system. Fans are hot-swapped and can be replaced without powering down the system. The electrical connections are automatically made when a fan is inserted into its slot.

Make sure the chassis cover is only off for a short time and makes a good seal when replaced for the cooling air to circulate properly through the system.

Fan speed is controlled by a system temperature setting in IPMI. If a fan fails, the remaining fans will ramp up to full speed. Replace any failed fan at your earliest convenience with the same type and model.

### *Changing a System Fan*

1. Determine which fan is failing using BMC if possible. If not, remove the chassis cover while the power is on and examine the fans to determine which one has failed.
2. Squeeze the fan tabs of the failed fan and lift the fan housing up and out of the chassis.
3. To install a fan, push it into the proper location until it clicks.
4. Finish by fully closing the cover and pushing the system back into the rack.

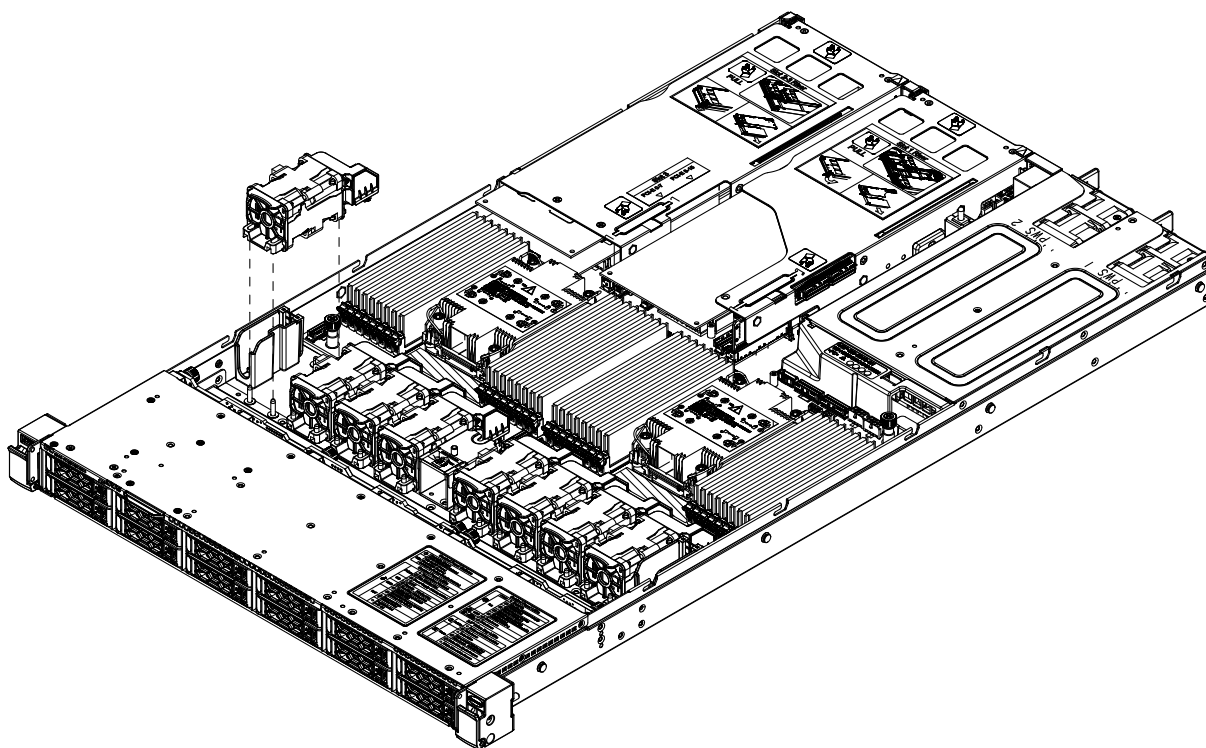

Figure 3-8. Installing a Fan

## Air Shrouds

Air shrouds concentrate airflow to maximize fan efficiency. The AS -1125HS-TNR includes one air shroud for each CPU.

### ***Air Shroud for Memory (CPU1/2)***

Two air shrouds cool the DIMM slots controlled by CPUs 1 and 2 (see figure below).

1. Remove the system from the rack and remove the cover as described [previously](#).
2. Place each air shroud over twelve DIMM slots at a time for both CPU1 and CPU2-controlled DIMM slots, as illustrated below.
3. Close the cover and push the system back into the rack.

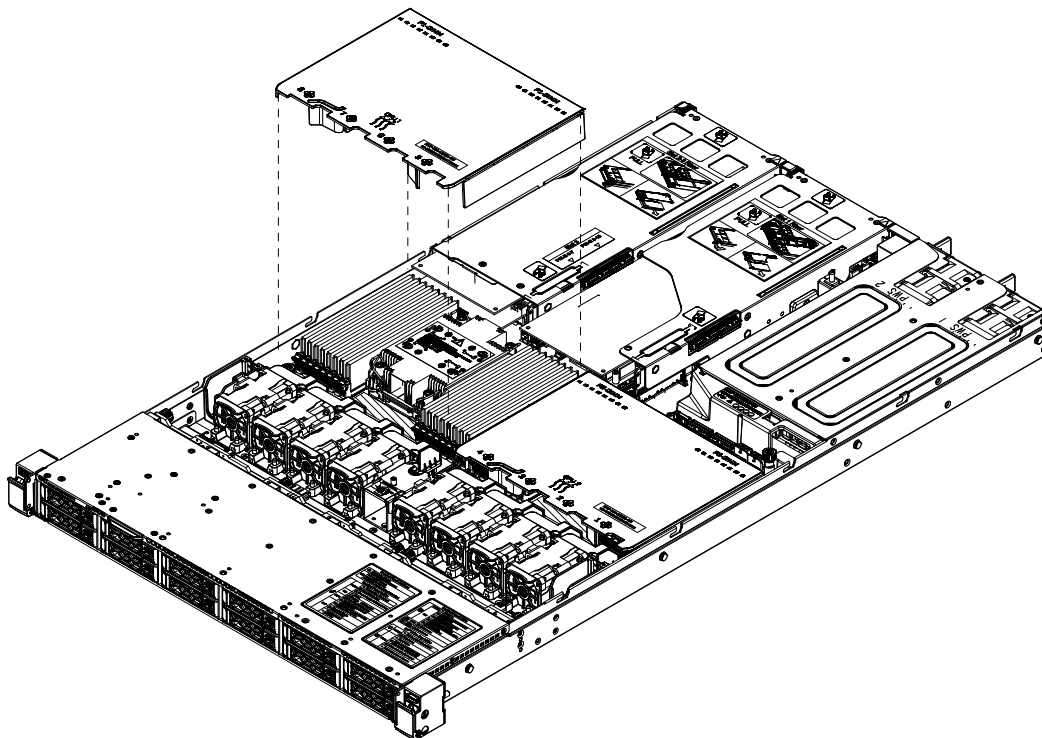

**Figure 3-9. Installing Air Shrouds for CPU1/2 DIMMS**

## 3.8 Expansion Cards

The AS -1125HS-TNR includes two riser cards to support the use of expansion (add-on) cards.

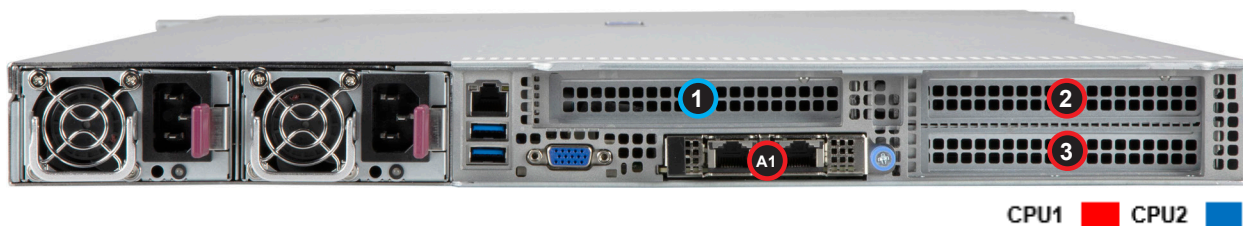

Figure 3-10. Expansion Card Chassis Slots

### Riser Cards

This system include riser cards that provide PCIe capabilities.

PCIe Slots per Riser Card			
Riser Card	Part Number	Slot	Description (all PCIe 5.0)
Right (from rear)	RSC-H-66G5L	2	x16 FH, 10.5"L (CPU1)
		3	x16 FH, 10.5"L (CPU2)
Left (from rear)	RSC-H-6G5L	1	x16 FH, 6.6"L (CPU2)

Full-height = 4.2", Low-profile = 2.5", Full-length = 10.5", Half-length = 6.6"

The AS -1125HS-TNR includes two riser cards to support the use of expansion (add-on) cards. Before following the procedure below to install expansion cards, first turn off and remove power from the system as described in section 3.1 then remove the top cover.

### ***Installing Expansion Cards***

1. Open any clips next to the slots and remove the PCI shield.
2. Install the riser card to the riser bracket, if necessary.
3. Install one or two expansion cards into the riser card. See the next page for M.2 SSD installation.
4. Insert the riser card bracket with the expansion cards into the chassis rear and connect cables.
5. Close any opened clips to secure the riser card bracket.

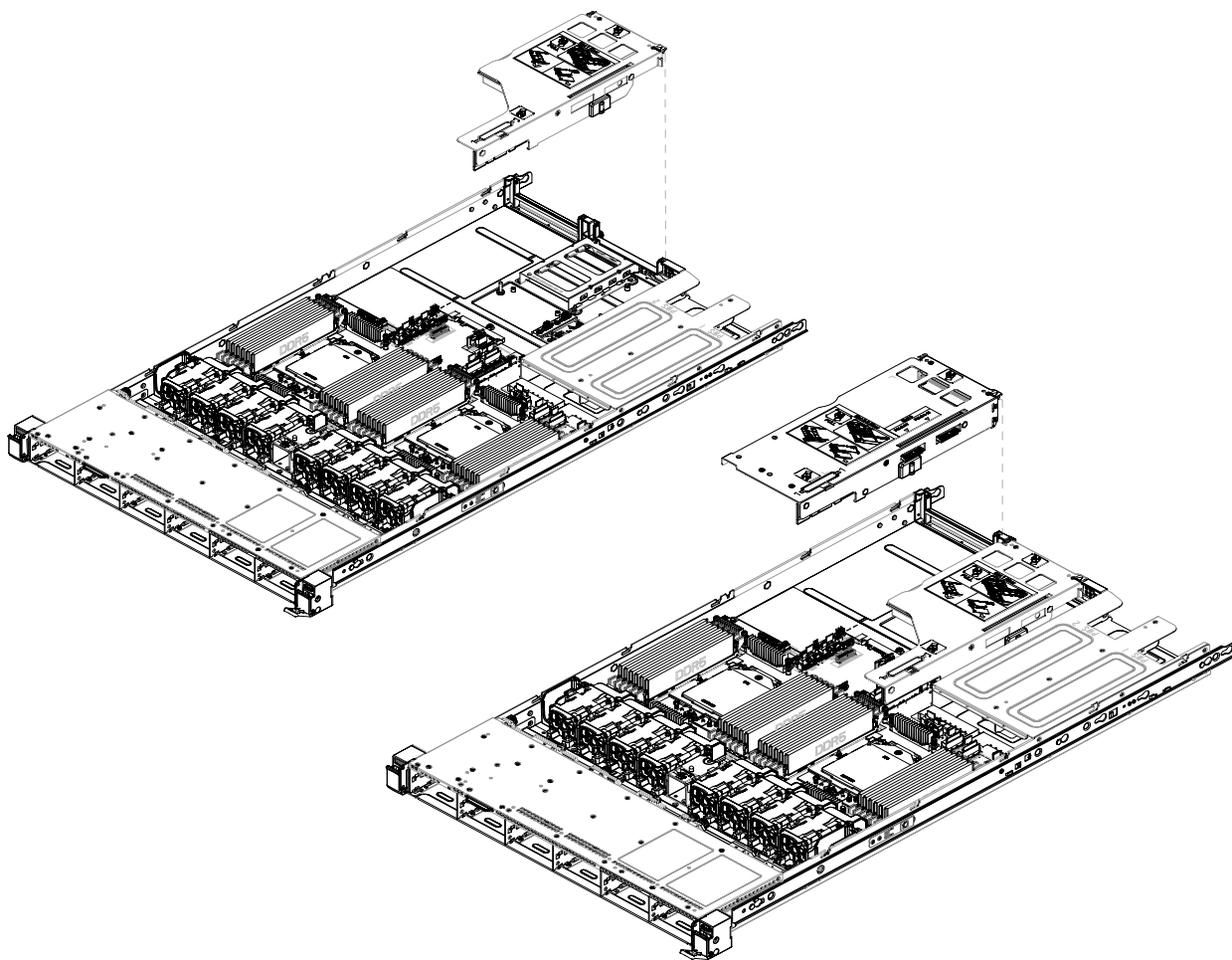

**Figure 3-11. Installing Expansion Cards**

## Installing M.2 Solid State Drives on Motherboard

The H13DSH motherboard has two PCIe 3.0 x4 NVMe M.2 slots (M.2-C1, M.2-C2). M.2 allows for a variety of card sizes, increased functionality, and spatial efficiency.

### Installing M.2 SSDs

1. Remove power from the system and then remove the top cover as described in Sections 3.1 and 3.2.
2. Refer to its layout image in the [Motherboard manual](#) and locate the M.2 slot. Insert the plastic clip into the hole against the M.2 slot on the motherboard.
3. Turn the plastic clip by 90° degrees.
4. Insert the M.2 sideways into the connector so that it lays flat, then secure it to the motherboard with the plastic clip.
5. Repeat as necessary for more M.2 drives.
6. Finish by replacing the cover and restoring power to the system.

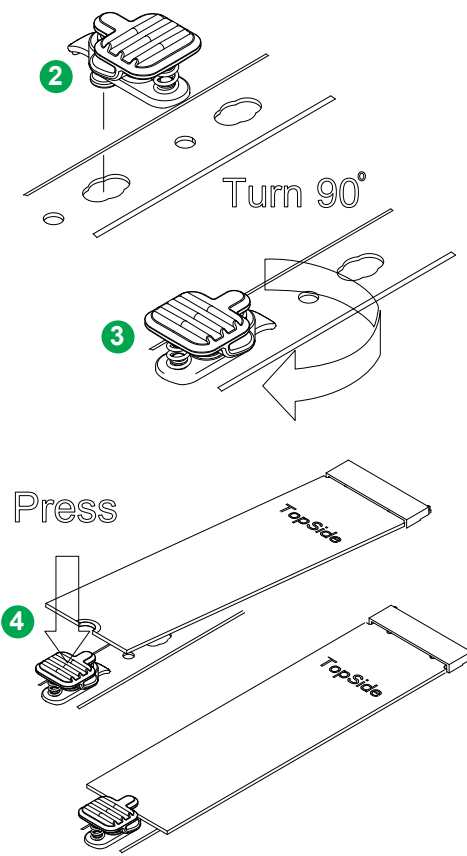

Figure 3-12. Installing an M.2 SSD

## 3.9 AIOM Cards

The system supports up to one AIOM/OCP NIC 3.0 network port card.



Figure 3-13. AIOM Chassis Slot

AIOM Configuration			
Slot	Mechanical	Electrical	Thermal
A1	Small Form Factor, OCP 3.0	PCIe 5.0 x16 (CPU1)	Up to 50 W (see note below)

**Note:** AIOM cards exceeding the 15 W slot class may require restricted conditions to meet thermal specification of the AIOM card. Contact your Supermicro account representative for more information.

### Installing AIOM

1. Remove the blank cover plate (A1), unscrewing the thumbscrew.
2. Slide the AIOM card in the opening until it seats in the motherboard slot.
3. Secure with the thumbscrew.

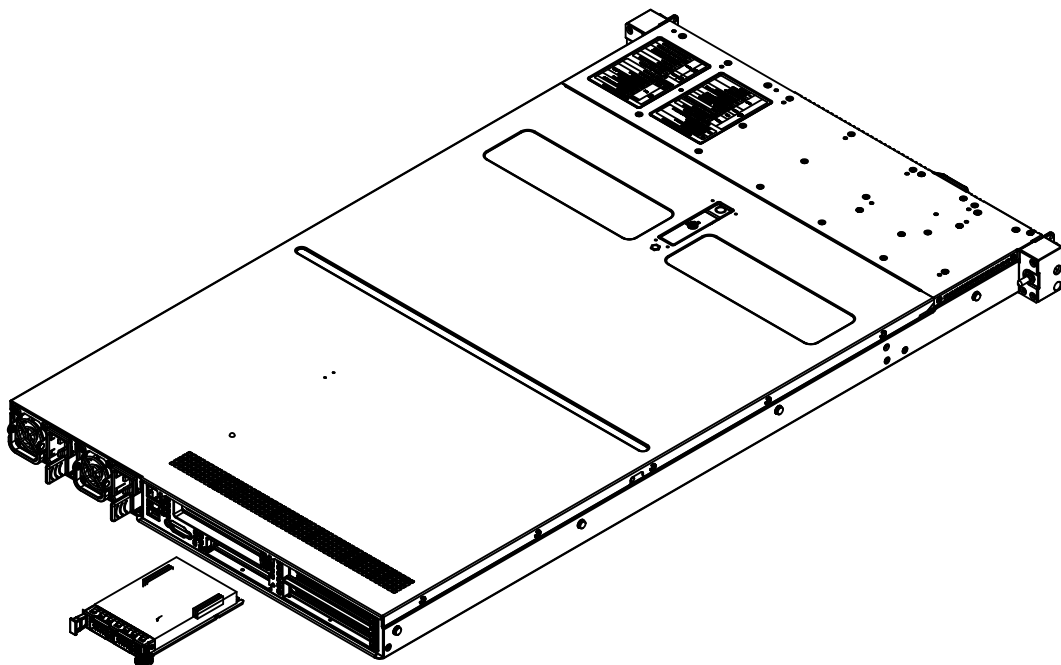

Figure 3-14. Installing AIOM

## 3.10 Power Supply

The system includes two hot-plug power supply modules. These modules will automatically sense and operate at an input voltage between 100V to 240V. Note that different input voltages will result in different maximum power output levels.

In the event of a power module failure, the other power module will continue to power the system on its own. Failed power supply modules can be replaced without powering down the system. Replacement modules can be ordered directly from Supermicro.

An amber light on the power supply is illuminated when the power is switched off. A green light indicates that the power supply is operating.

### ***Replacing the Power Supply***

1. Unplug the AC power cord from the failed power supply module.
2. Push and hold the release tab on the back of the power supply.
3. Grasp the handle of the power supply and pull it out of its bay.
4. Push the new power supply module into the power bay until it clicks into the locked position.
5. Plug the AC power cord back into the power supply module.

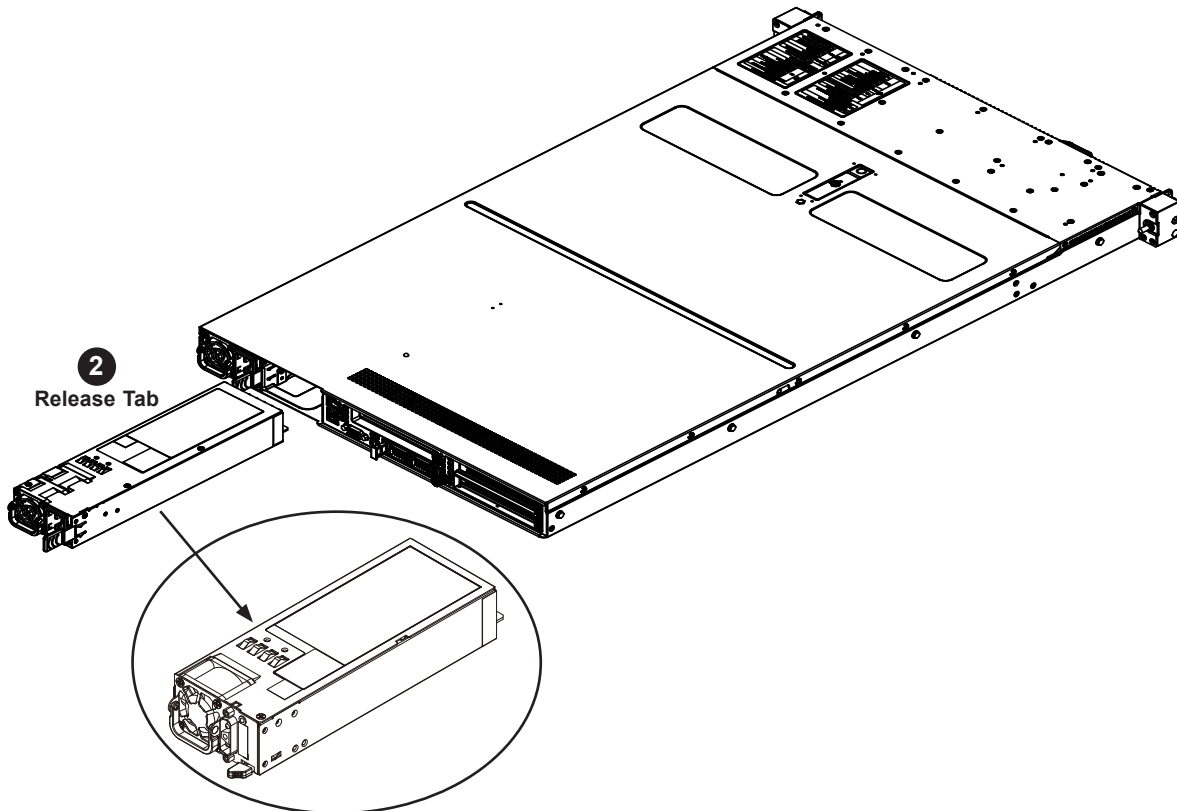

**Figure 3-15. Installing a Power Supply Module**

## 3.11 Cable Routing Diagrams

### Eight NVMe

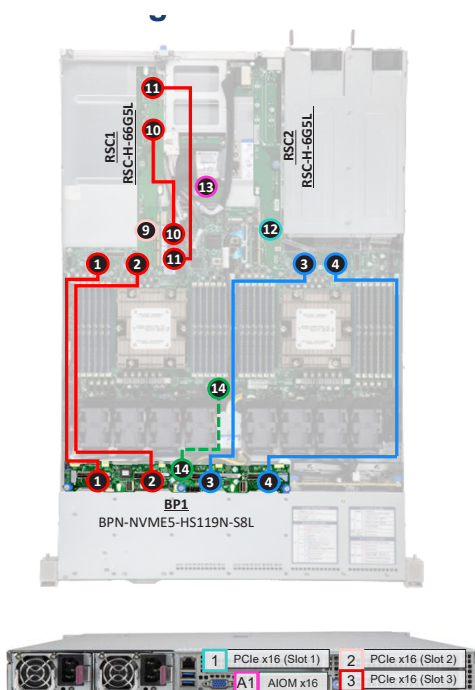

- MCIO port from CPU 1
- MCIO port from CPU 2
- Power Cable/I2C
- AIOM slot from CPU 1
- MCIO port for SATA from CPU 2
- Riser slot from CPU 1
- Riser slot from CPU 2

#### Front Storage Cables

	Cable	Description	MB Port	Backplane/Riser and Port
1	CBL-MCIO-1356M5FHB (Bundled Cable)	NVMe 0-1	JMCIO1	<b>BP1</b> CN1
		NVMe 2-3	JMCIO2	<b>BP1</b> CN2
3	CBL-MCIO-1242M5REL	NVMe 4-5	JMICO7	<b>BP1</b> CN3
4	CBL-MCIO-1359M5FRF	NVMe 6-7	JMCIO8	<b>BP1</b> CN4
14	CBL-PWEX-1142B-20	<b>BP1</b> Power	JPW9/ JPW5*	JPW1

\* MB Port on MB Rev. 1.01A

#### Rear PCIe Slot Cables

	Cable	Description	MB Port	Backplane/Riser and Port
9	N/A	PCIe x16 (Slot 2)	JPCIE1	<b>RSC2</b> Gold Finger
10	CBL-MCIO-1221M5RE	PCIe x16 (Slot 3)	JMCIO4	<b>RSC2</b> JPCIE2A1
11			JMCIO3	<b>RSC2</b> JPCIE2B1
12	N/A	PCIe x16 (Slot 1)	JPCIE2	<b>RSC1</b> Gold Finger
13	CBL-GNZ5-1307	AIOM x16 (AIOM 1)	JAIOM1	N/A

## Eight SATA

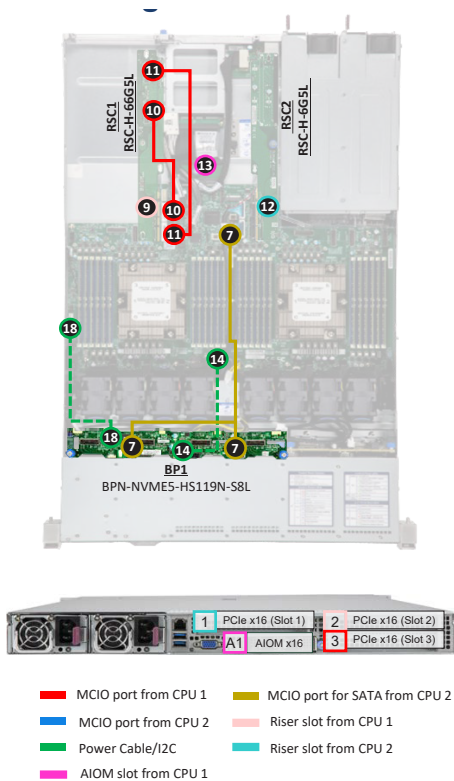

### Front Storage Cables

	Cable	Description	MB Port	Backplane/Riser and Port
7	CBL-MCIO-1255L4Y	SATA 0-7	JMCIO5	<b>BP1</b> JSM1/JSM2
14	CBL-PWEX-1142B-20	<b>BP1</b> Power	JPW9/ JPW5*	JPW1
18	CBL-CDAT-1062Y-45	I2C cable	JVNI2C1	<b>BP1</b> J25

\* MB Port on MB Rev. 1.01A

### Rear PCIe Slot Cables

	Cable	Description	MB Port	Backplane/Riser and Port
9	N/A	PCIe x16 (Slot 2)	JPCIE1	<b>RSC2</b> Gold Finger
10	CBL-MCIO-1221M5RE	PCIe x16 (Slot 3)	JMCIO4	<b>RSC2</b> JPCIE2A1
11	CBL-MCIO-1228M5RE		JMCIO3	<b>RSC2</b> JPCIE2B1
12	N/A	PCIe x16 (Slot 1)	JPCIE2	<b>RSC1</b> Gold Finger
13	CBL-GNZ5-1307	AIOM x16 (AIOM 1)	JAIOM1	N/A

## Eight SAS

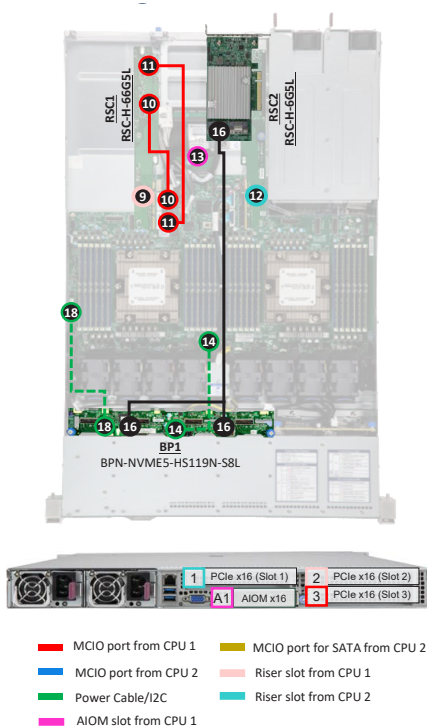

### Front Storage Cables

	Cable	Description	MB Port	Backplane/Riser and Port
14	CBL-PWEX-1142B-20	BP1 Power	JPW9/ JPW5*	JPW1
16	CBL-SAST-1273LP-100	SAS 0-7	To SAS AOC	BP1 JSM1/JSM2
18	CBL-CDAT-1062Y-45	I2C cable	JVNI2C1	BP1 J25

\* MB Port on MB Rev. 1.01A

### Rear PCIe Slot Cables

	Cable	Description	MB Port	Backplane/Riser and Port
9	N/A	PCIe x16 (Slot 2)	JPCIE1	RSC2 Gold Finger
10	CBL-MCIO-1221M5RE	PCIe x16 (Slot 3)	JMCIO4	RSC2 JPCIE2A1
11	CBL-MCIO-1228M5RE		JMCIO3	RSC2 JPCIE2B1
12	N/A	PCIe x16 (Slot 1)	JPCIE2	RSC1 Gold Finger
13	CBL-GNZ5-1307	AIOM x16 (AIOM 1)	JAIOM1	N/A

## Twelve NVMe

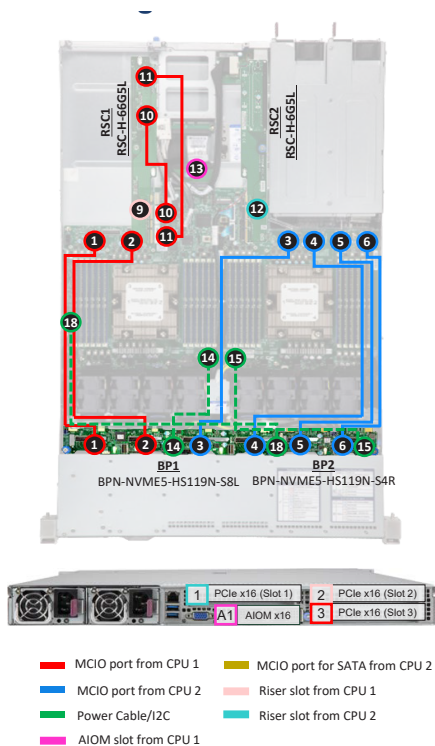

### Front Storage Cables

	Cables/ Parts	Description	MB Port	Backplane/Riser and Port
1	CBL-MCIO-1356M5FHB (Bundled Cable)	NVMe 0-1	JMCIO1	BP1 CN1
2		NVMe 2-3	JMCIO2	BP1 CN2
3	CBL-MCIO-1242M5REL	NVMe 4-5	JMICO7	BP1 CN3
4	CBL-MCIO-1359M5FRF	NVMe 6-7	JMCIO8	BP1 CN4
5	CBL-MCIO-1352M5FRF	NVMe 8-9	JMCIO9	BP2 CN1
6	CBL-MCIO-1343M5FRF	NVMe 10-11	JMCIO10	BP2 CN2
14	CBL-PWEX-1142B-20	BP1 Power	JPW9/JPW5*	JPW1
15	CBL-PWEX-1136-40	BP2 Power	JPW8/JPW4*	JPWR1
18	CBL-CDAT-1062Y-45	I2C cable	JVNI2C1	BP2 J25

\* MB Port on MB Rev. 1.01A

### Rear PCIe Slot Cables

	Cable	Description	MB Port	Backplane/Riser and Port
9	N/A	PCIe x16 (Slot 2)	JPCIE1	RSC2 Gold Finger
10	CBL-MCIO-1221M5RE	PCIe x16 (Slot 3)	JMCIO4	RSC2 JPCIE2A1
11			JMCIO3	RSC2 JPCIE2B1
12	N/A	PCIe x16 (Slot 1)	JPCIE2	RSC1 Gold Finger
13	CBL-GNZ5-1307	AIOM x16 (AIOM 1)	JAIOM1	N/A

## Twelve SATA

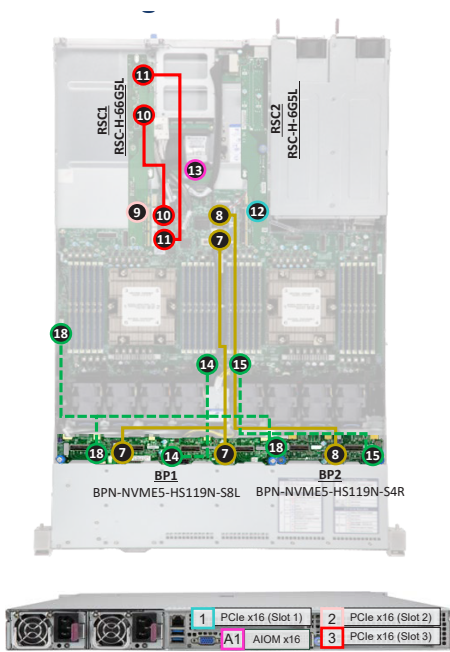

- MCIO port from CPU 1
- MCIO port from CPU 2
- Power Cable/I2C
- AIOM slot from CPU 1
- MCIO port for SATA from CPU 2
- Riser slot from CPU 1
- Riser slot from CPU 2

### Front Storage Cables

	Cables/ Parts	Description	MB Port	Backplane/Riser and Port
7	CBL-MCIO-1255L4Y	SATA 0-7	JMCIO5	<u>BP1</u> JSM1/JSM2
8	CBL-MCIO-1255L4Y	SATA 8-11	JMCIO6	<u>BP2</u> JSM1
14	CBL-PWEX-1142B-20	<u>BP1</u> Power	JPW9/ JPW5*	JPW1
15	CBL-PWEX-1136-40	<u>BP2</u> Power	JPW8/ JPW4*	JPWR1
18	CBL-CDAT-1062Y-45	I2C cable	JVNI2C1	<u>BP1</u> J25 <u>BP2</u> J25

\* MB Port on MB Rev. 1.01A

### Rear PCIe Slot Cables

	Cable	Description	MB Port	Backplane/Riser and Port
9	N/A	PCIe x16 (Slot 2)	JPCIE1	<u>RSC2</u> Gold Finger
10	CBL-MCIO-1221M5RE	PCIe x16 (Slot 3)	JMCIO4	<u>RSC2</u> JPCIE2A1
11	CBL-MCIO-1228M5RE		JMCIO3	<u>RSC2</u> JPCIE2B1
12	N/A	PCIe x16 (Slot 1)	JPCIE2	<u>RSC1</u> Gold Finger
13	CBL-GNZ5-1307	AIOM x16 (AIOM 1)	JAIOM1	N/A

## Twelve SAS

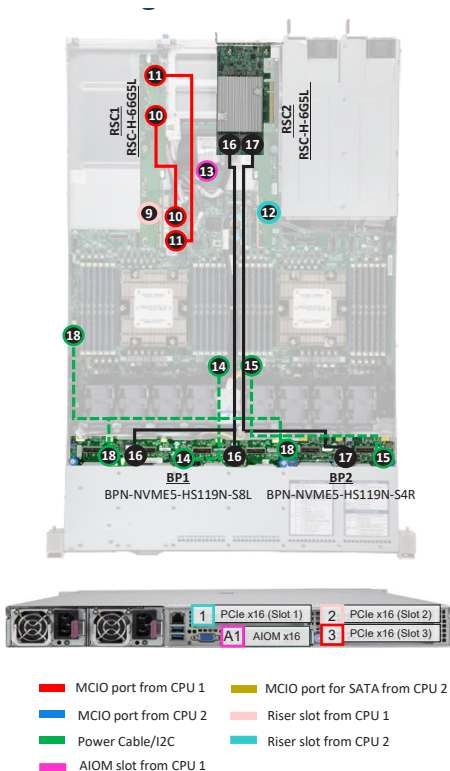

### Front Storage Cables

	Cables/ Parts	Description	MB Port	Backplane/Riser and Port
14	CBL-PWEX-1142B-20	<b>BP1</b> Power	JPW9/ JPW5*	JPW1
15	CBL-PWEX-1136-40	<b>BP2</b> Power	JPW8/ JPW4*	JPWR1
16	CBL-SAST-1273LP-100	SAS 0-7	To SAS AOC	<b>BP1</b> JSM1/JSM2
17	CBL-SAST-1262LP-100	SAS 8-11	To SAS AOC	<b>BP2</b> JSM1
18	CBL-CDAT-1062Y-45	I2C cable	JVNI2C1	<b>BP1</b> J25 <b>BP2</b> J25

\* MB Port on MB Rev. 1.01A

### Rear PCIe Slot Cables

	Cable	Description	MB Port	Backplane/Riser and Port
9	N/A	PCIe x16 (Slot 2)	JPCIE1	<b>RSC2</b> Gold Finger
10	CBL-MCIO-1221M5RE	PCIe x16 (Slot 3)	JMCIO4	<b>RSC2</b> JPCIE2A1
11	CBL-MCIO-1228M5RE		JMCIO3	<b>RSC2</b> JPCIE2B1
12	N/A	PCIe x16 (Slot 1)	JPCIE2	<b>RSC1</b> Gold Finger
13	CBL-GNZ5-1307	AIOM x16 (AIOM 1)	JAIOM1	N/A

## Eight NVMe + Four SATA

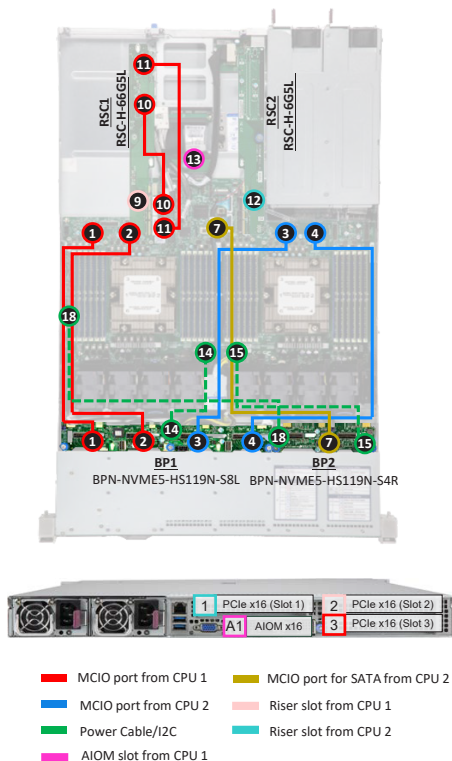

### Front Storage Cables

	Cable	Description	MB Port	Backplane/Riser and Port
1	CBL-MCIO-1356M5FHB (Bundled Cable)	NVMe 0-1	JMCIO1	<u>BP1</u> CN1
2		NVMe 2-3	JMCIO2	<u>BP1</u> CN2
3	CBL-MCIO-1242M5REL	NVMe 4-5	JMICO7	<u>BP1</u> CN3
4	CBL-MCIO-1359M5FRF	NVMe 6-7	JMCIO8	<u>BP1</u> CN4
7	CBL-MCIO-1255L4Y	SATA 0-3	JMCIO5	<u>BP2</u> JSM1
14	CBL-PWEX-1142B-20	<u>BP1</u> Power	JPW9/ JPW5*	JPW1
15	CBL-PWEX-1136-40	<u>BP2</u> Power	JPW8/ JPW4*	JPWR1
18	CBL-CDAT-1062Y-45	I2C cable	JVNI2C1	<u>BP2</u> J25

\* MB Port on MB Rev. 1.01A

### Rear PCIe Slot Cables

	Cable	Description	MB Port	Backplane/Riser and Port
9	N/A	PCIe x16 (Slot 2)	JPCIE1	<u>RSC2</u> Gold Finger
10	CBL-MCIO-1221M5RE	PCIe x16 (Slot 3)	JMCIO4	<u>RSC2</u> JPCIE2A1
11			JMCIO3	<u>RSC2</u> JPCIE2B1
12	N/A	PCIe x16 (Slot 1)	JPCIE2	<u>RSC1</u> Gold Finger
13	CBL-GNZ5-1307	AIOM x16 (AIOM 1)	JAIOM1	N/A

## Eight NVMe + Four SAS

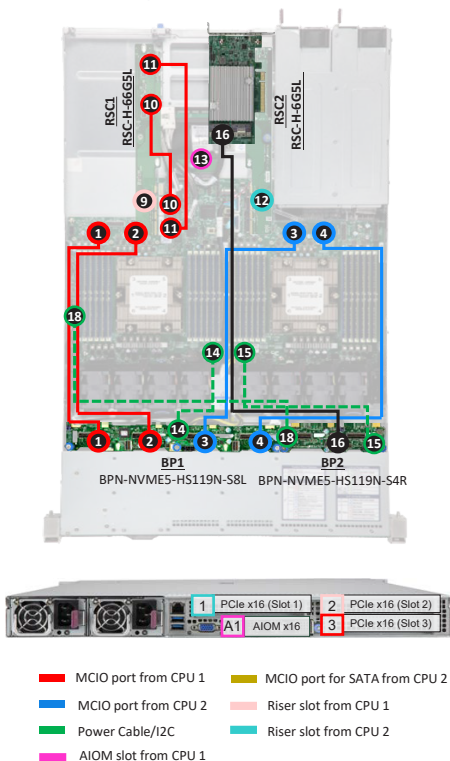

### Front Storage Cables

	Cables/ Parts	Description	MB Port	Backplane/Riser and Port
1	CBL-MCIO-1356M5FHB (Bundled Cable)	NVMe 0-1	JMCIO1	<b>BP1</b> CN1
2		NVMe 2-3	JMCIO2	<b>BP1</b> CN2
3	CBL-MCIO-1242M5REL	NVMe 4-5	JMCIO7	<b>BP1</b> CN3
4	CBL-MCIO-1359M5FRF	NVMe 6-7	JMCIO8	<b>BP1</b> CN4
14	CBL-PWEX-1142B-20	<b>BP1</b> Power	JPW9/ JPW5*	JPW1
15	CBL-PWEX-1136-40	<b>BP2</b> Power	JPW8/ JPW4*	JPWR1
16	CBL-SAST-1262LP-100	SAS 0-3	To SAS AOC	<b>BP2</b> JSM1
18	CBL-CDAT-1062Y-45	I2C cable	JVN12C1	<b>BP2</b> J25

\* MB Port on MB Rev. 1.01A

### Rear PCIe Slot Cables

	Cable	Description	MB Port	Backplane/Riser and Port
9	N/A	PCIe x16 (Slot 2)	JPCIE1	<b>RSC2</b> Gold Finger
10	CBL-MCIO-1221M5RE	PCIe x16 (Slot 3)	JMCIO4	<b>RSC2</b> JPCIE2A1
11			JMCIO3	<b>RSC2</b> JPCIE2B1
12	N/A	PCIe x16 (Slot 1)	JPCIE2	<b>RSC1</b> Gold Finger
13	CBL-GNZ5-1307	AIOM x16 (AIOM 1)	JAIOM1	N/A

## Chapter 4

# Motherboard Connections

This section describes the connections on the motherboard and provides pinout definitions. Note that depending on how the system is configured, not all connections are required. The LEDs on the motherboard are also described here. A motherboard layout indicating component locations may be found in [Chapter 1](#). More detail can be found in the [Motherboard Manual](#). Please review the Safety Precautions in [Appendix A](#) before installing or removing components.

### 4.1 Power Connections

#### Power Connectors

JPW1 to JPW11 are the 8-pin power connectors for GPU, BPN and AOC power.

8-pin GPU Power Pin Definitions	
Pin#	Definition
1-11	Power 12V, GPU, BPN and AOC

#### Onboard Battery

The onboard backup battery is located at BT1. The onboard battery provides backup power to the on chip CMOS, which stores the BIOS' setup information. It also provides power to the Real Time Clock (RTC) to keep it running.

## 4.2 Headers and Connectors

### External BMC I2C Header

A System Management Bus header for IPMI 2.0 is located at JIPMB1. Connect a cable to this header to use the IPMB I<sup>2</sup>C connection on your system. Refer to the table below for pin definitions.

External I <sup>2</sup> C Header Pin Definitions	
Pin#	Definition
1	Data
2	Ground
3	Clock
4	No Connection

### NC-SI Connector

A Network-Controller Sideband Interface (NC-SI) header is located at JNCSI1 on the motherboard. The NCSI header is used to connect a Network Interface Card (NIC) to the motherboard so that the BMC is able to poll the temperature reading from it.

**Note:** For detailed instructions on how to configure Network Interface Card (NIC) settings, refer to the Network Interface Card Configuration User's Guide posted on the web page under the link: <http://www.supermicro.com/manuals/>.

### TPM/Port 80 Header

A Trusted Platform Module (TPM)/Port 80 header is located at JTPM1 to provide TPM support and Port 80 connection. Use this header to enhance system performance and data security. Refer to the table below for pin definitions. Please go to the following link for more information on the TPM: <http://www.supermicro.com/manuals/other/TPM.pdf>.

Trusted Platform Module Header Pin Definitions			
Pin#	Definition	Pin#	Definition
1	+3.3V	2	SPI_CS#
3	RESET#	4	SPI_MISO
5	SPI_CLK	6	GND
7	SPI_MOSI	8	NC
9	+3.3V Stdby	10	SPI_IRQ#

### NVMe Ports (NVMe P1\_0~7, P2\_0~11)

The H13DSH has 20 NVMe ports (2 ports per 1 MCIO x 8) on the motherboard. These ports provide high speed and low latency directly from the CPU to NVMe Solid State (SSD) drives. This greatly increases SSD data-throughput performance and significantly reduces PCIe latency by simplifying driver/software requirements resulting from direct PCIe interface from the CPU to the NVMe SSD drives.

**SATA/NVMe Hybrid Ports (P1\_NVMe 0/1, P1\_SATA 0-7; P1\_NVMe 2/3, P1\_SATA 8-15; P2\_NVMe 0/1, P2\_SATA 0-7; P2\_NVMe 2/3, P2\_SATA8-15)**

Each SATA/NVMe hybrid port can support up to eight SATA 3.0 ports or two NVMe ports (PCIe x4), for a total of thirty-two SATA ports or eight NVMe ports.

**Expansion Slots**

The motherboard features two expansion slots (JPCIE1 and JPCIE2). These are both PCIe 5.0 x16 slots (JPCIE1 is for a left-hand riser card and JPCIE2 is for a right-hand riser card).

**AIOM Slot**

An Advanced I/O Module (AIOM) slot supports a networking adapter card with multiple RJ45 ports. This slot also supports NC-SI.

## 4.3 Input/Output Ports

### *I/O Ports*

The low-profile slimSAS I/O connector, located at JIO1, is used to connect the motherboard to an I/O mezzanine board, AOM-HS119-IO, to provide VGA/COM/BMC/USB connections.

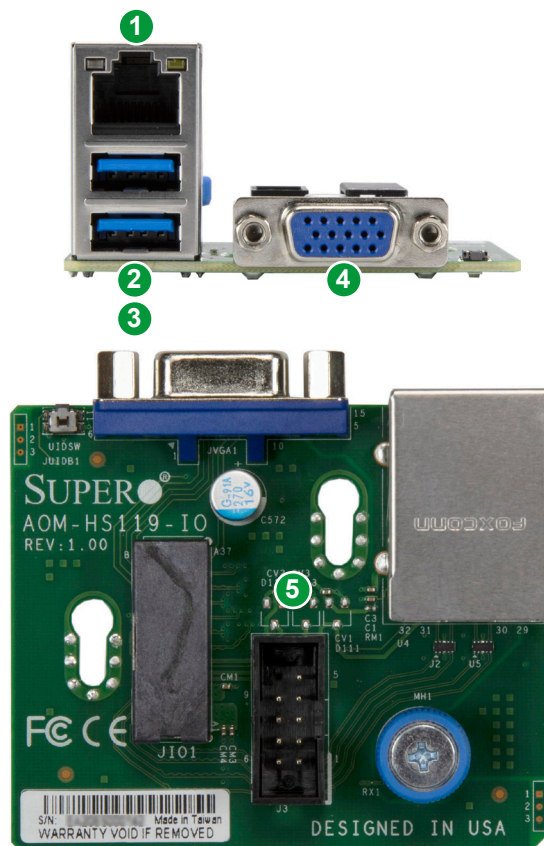

I/O Ports from AOM-HS119-IO	
#	Description
1	BMC_LAN Port
2	USB 0 (3.2 Gen 1)
3	USB 1 (3.2 Gen 1)
4	VGA Port
5	COM Port Header

### **VGA Connections**

A VGA header is located at JFP2 on the motherboard.

## 4.4 Jumper Settings

### How Jumpers Work

To modify the operation of the motherboard, jumpers can be used to choose between optional settings. Jumpers create shorts between two pins to change the function of the connector. Pin #1 is identified with a square solder pad on the printed circuit board. See the diagram below for an example of jumping pins 1 and 2. Refer to the motherboard layout page for jumper locations.

**Note:** On two-pin jumpers, "Closed" means the jumper is on and "Open" means the jumper is off the pins.

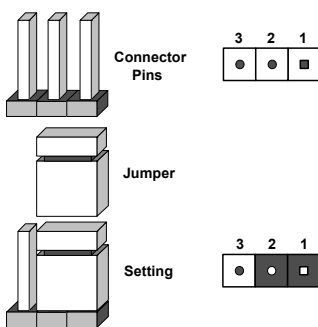

### CMOS Clear (JBT1)

JBT1 is used to clear CMOS, which will also clear any passwords. Instead of pins, this jumper consists of contact pads to prevent accidentally clearing the contents of CMOS.

#### To Clear CMOS

1. First power down the system and unplug the power cord(s).
2. Remove the cover of the chassis to access the motherboard.
3. Remove the CMOS battery from the motherboard.
4. Short the CMOS pads with a metal object such as a small screwdriver for at least four seconds.
5. Remove the screwdriver (or shorting device).
6. Re-install the CMOS battery on the motherboard.
7. Replace the cover, reconnect the power cord(s), and power on the system.

**Note:** Clearing CMOS will also clear all passwords.

Do not use the PW\_ON connector to clear CMOS.



**JSATA1/JSATA2**

The 3-pin jumpers at JSATA1 and JSATA2 provide the option to switch the hybrid port (JMCI0 1/2/5/6) between SATA/NVMe. Refer to the table below for pin definitions.

<b>JSATA1/JSATA2 Pin Definitions</b>	
<b>Pin#</b>	<b>Definition</b>
1-2	Auto (Depends on system configuration)
2-3	SATA
Open	NVMe

## 4.5 LED Indicators

### Onboard Power LED

LED\_PWR is an onboard power LED. When this LED is lit, it means system is in the power-on state, and the onboard power status is ok. Turn off the system and unplug the power cord before removing or installing components.

Onboard Power LED Indicator	
LED Color	Definition
Off	System Off (power cable not connected)
Green	System On, Power OK

### BMC Heartbeat LED

A BMC Heartbeat LED is located at LED BMC on the serverboard. When LED BMC is blinking, BMC is functioning normally. See the table below for more information.

BMC Heartbeat LED States		
Color	State	Definition
Green	Solid On	BMC is not ready.
Green	Blinking	BMC Normal
Green	Fast Blinking	BMC: Initializing

# Chapter 5

## Software

After the hardware has been installed, you can install the Operating System (OS), configure RAID settings, and install the drivers.

### 5.1 Microsoft Windows OS Installation

If you will be using RAID, you must configure RAID settings before installing the Windows OS and the RAID driver. Refer to the RAID Configuration User Guides posted on our website at [www.supernmicro.com/support/manuals](http://www.supernmicro.com/support/manuals).

#### *Installing the OS*

1. Create a method to access the Microsoft Windows installation ISO file. That can be a USB flash or media drive.
2. Retrieve the proper RST/RSTe driver. Go to the Supermicro web page for your motherboard and click on "Download the Latest Drivers and Utilities", select the proper driver, and copy it to a USB flash drive.
3. Boot from a bootable device with Windows OS installation. You can see a bootable device list by pressing **F11** during the system startup.

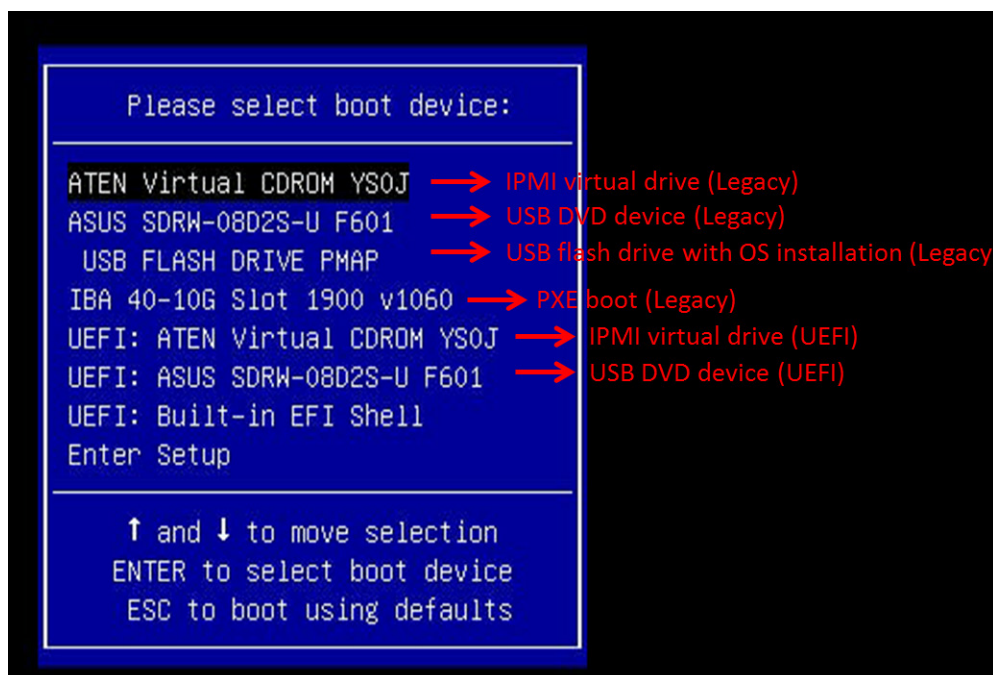
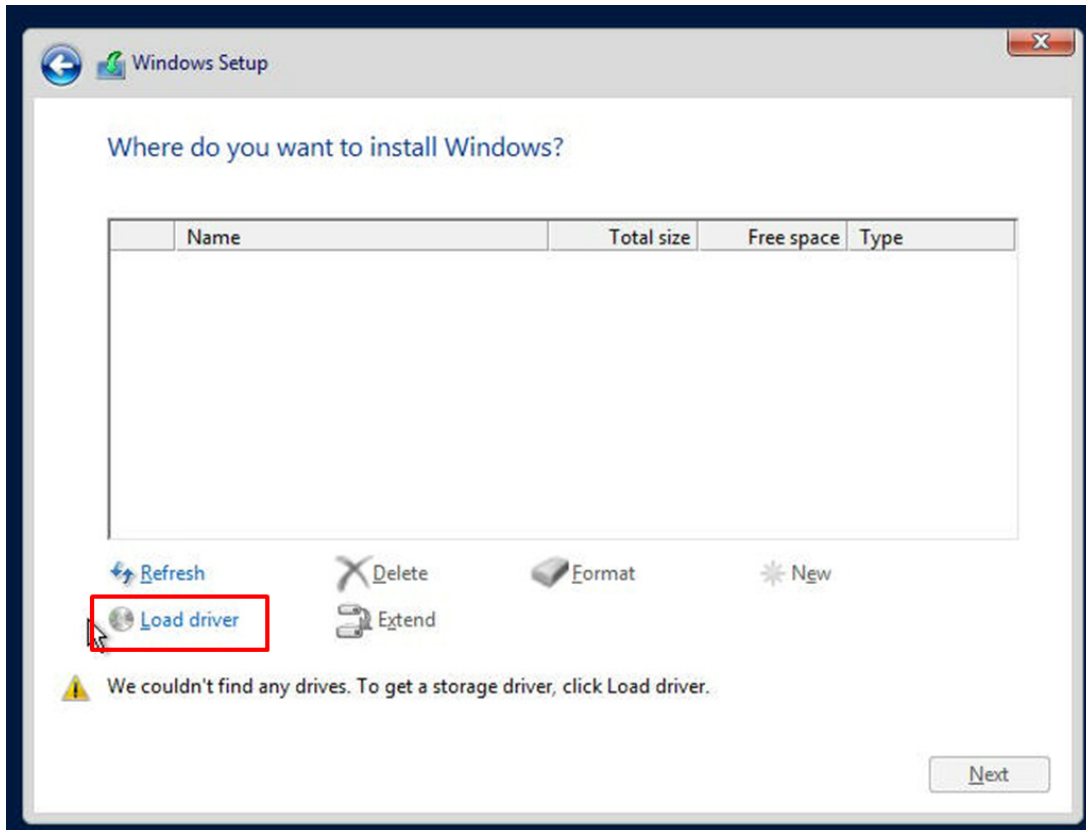

Figure 5-1. Select Boot Device

4. During Windows Setup, continue to the dialog where you select the drives on which to install Windows. If the disk you want to use is not listed, click on “Load driver” link at the bottom left corner.



**Figure 5-2. Load Driver Link**

To load the driver, browse the USB flash drive for the proper driver files.

- For RAID, choose the SATA/sSATA RAID driver indicated then choose the storage drive on which you want to install it.
  - For non-RAID, choose the SATA/sSATA AHCI driver indicated then choose the storage drive on which you want to install it.
5. Once all devices are specified, continue with the installation.
  6. After the Windows OS installation has been completed, the system will automatically reboot multiple times.

## 5.2 Driver Installation

The Supermicro website contains drivers and utilities for your system at <https://www.supermicro.com/wdl/driver>. Some of these must be installed, such as the chipset driver.

After accessing the website, go into the CDR\_Images (in the parent directory of the above link) and locate the ISO file for your motherboard. Download this file to a USB flash or media drive. (You may also use a utility to extract the ISO file if preferred.)

Another option is to go to the Supermicro website at <http://www.supermicro.com/products/>. Find the product page for your motherboard, and "Download the Latest Drivers and Utilities". Insert the flash drive or disk, and the screenshot shown below should appear.

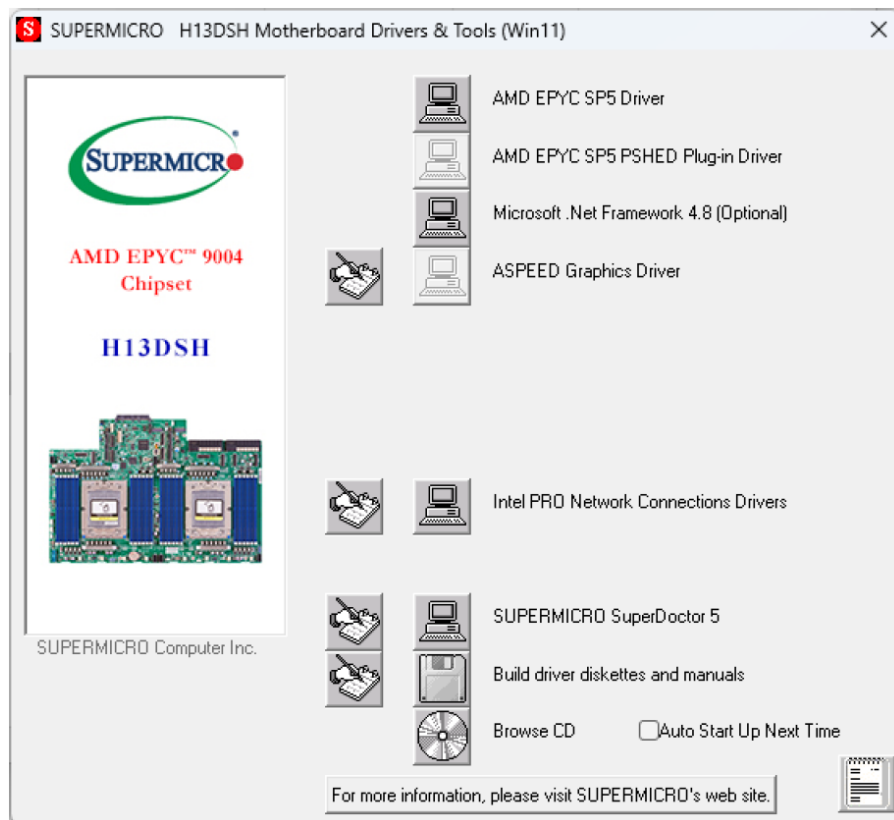

**Figure 5-3. Driver and Tool Installation Screen**

**Note:** Click the icons showing handwriting on paper to view the readme files for each item. Click the computer icons to the right of these items to install each item (from the top to the bottom) one at a time. **After installing each item, you must reboot the system before moving on to the next item on the list.** The bottom icon with a CD on it allows you to view the entire content.

## 5.3 SuperDoctor® 5

The Supermicro SuperDoctor 5 is a program that functions in a command-line or web-based interface for Windows and Linux operating systems. The program monitors such system health information as CPU temperature, system voltages, system power consumption, fan speed, and provides alerts via email or Simple Network Management Protocol (SNMP).

SuperDoctor 5 comes in local and remote management versions and can be used with Nagios to maximize your system monitoring needs. With SuperDoctor 5 Management Server (SSM Server), you can remotely control power on/off and reset chassis intrusion for multiple systems with SuperDoctor 5 or IPMI. SuperDoctor 5 Management Server monitors HTTP, FTP, and SMTP services to optimize the efficiency of your operation.

[SuperDoctor® Manual and Resources](#)

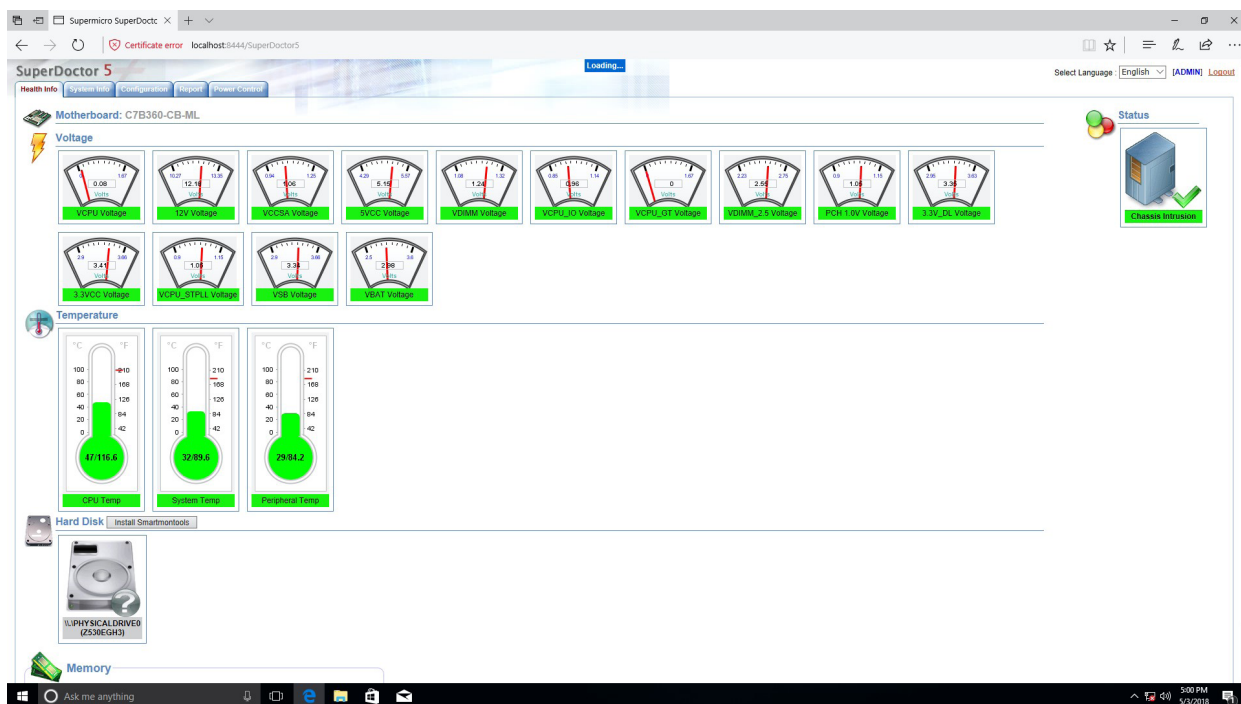

Figure 5-4. SuperDoctor 5 Interface Display Screen (Health Information)

## 5.4 IPMI

The H13DSH supports the Intelligence Platform Management Interface (IPMI). IPMI is used to provide remote access, monitoring and management. There are several BIOS settings that are related to IPMI.

Supernmicro ships standard products with a unique password for the BMC ADMIN user. This password can be found on a label on the motherboard.

For general documentation and information on IPMI, please visit our website at: <http://www.supernmicro.com/products/nfo/IPMI.cfm>.

### BMC ADMIN User Password

For security, each system is assigned a unique default BMC password for the ADMIN user. This can be found on a sticker on the chassis and a sticker on the motherboard. The sticker also displays the BMC MAC address.



Figure 5-5. BMC Password Label

## Chapter 6

# Optional Components

This chapter describes alternate configurations and optional system components.

Optional Parts
Storage Drive Options
Storage Control Cards
Power Supply Modules
<a href="#">Cable Management Arm</a>
<a href="#">TPM Security Module</a>

### 6.1 Storage Drive Options

The storage drive bays can support SATA, SAS, and NVMe in any combination. To enable SAS, SATA, and NVMe, additional hardware is required.

**SATA** – The system can support up to eight SATA drives from the onboard SATA controller.

**SAS** – The system can support eight or twelve SAS drives with one of the supported add-on storage controller cards in section 6.2 Storage Control Cards.

**NVMe** – The system can support eight or twelve NVMe drives.

## 6.2 Storage Control Cards

Storage Control Card Options	
AOC SKU	Description
AOC-S3908L-H8iR-16DD	SAS RAID Adapter (RAID 0, 1, 5, 6, 10, 50, 60), eight internal SAS3 ports, Supports up to 16 physical devices with expander, One SlimSAS and eight black (100-Ohm) connector
AOC-S3916L-H16iR-32DD	SAS RAID Adapter (RAID 0, 1, 5, 6, 10, 50, 60), 16 internal SAS3 ports, Supports up to 32 physical devices with expander, Two SlimSAS eight black (100-Ohm) connectors
AOC-S3808L-L8iT	SAS Host Bus Adapter (IT mode), eight internal SAS3 ports, Supports up to 122 physical devices with expander, One SlimSAS and eight black (100-Ohm) connectors
AOC-S3816L-L16iT	SAS Host Bus Adapter (IT mode), 16 internal SAS3 ports, Supports up to 122 physical devices with expander, Two SlimSAS and eight black (100-Ohm) connectors

## 6.3 Power Supply Modules

Power Supply Module Options		
Watts	Part Number	80Plus Level
1200	PWS-1K24A-1R (default)	Titanium
1600	PWS-1K63A-1R	Titanium
2000	PWS-2K07A-1R	Titanium

## 6.4 Cable Management Arm

The system supports a cable management arm (CMA), which keeps the rear cables organized and clear of the rail mechanisms when the system is extended out the front of the rack for maintenance.

The CMA attaches to the rack mounting rails using four connectors. They are labeled on the connectors 1, 2, 3, and 4.

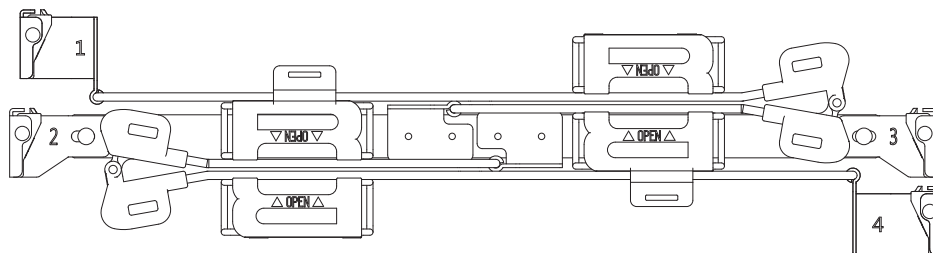
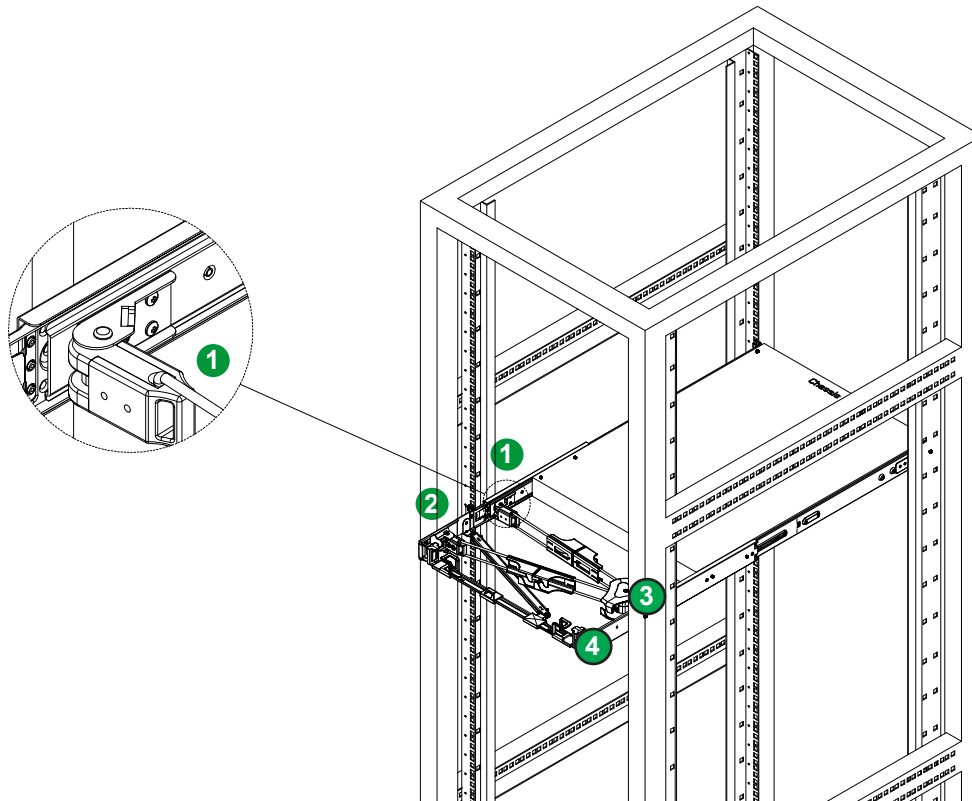

Figure 6-1. Cable Management Arm

Cable Arm Details		
Optional Part	Part Number	Description
Cable Arm	MCP-290-00168-0N	7.5" deep cable arm
Rail Set	MCP-290-11901-0N	41.2" rails (optimized for 1200 mm deep racks)

### Installing the Cable Management Arm

1. Slide CMA connector #1 forward onto the two posts on the rear of the right *inner* rail (right side when viewed from the front). It snaps into place.
2. Slide CMA connector #2 forward onto the two posts on the rear of the right *middle* rail. It snaps into place.



**Figure 6-2. Installing the Connectors**

3. Slide CMA connector #3 forward onto the two posts on the rear of the left middle rail. It snaps into place.
4. For CMA connector #4, align the metal tabs with the slots on the rear of the left outer rail and push it forward. It snaps into place.
5. Route the cables through the holding brackets, leaving enough slack.

#### ***Removing the Cable Management Arm***

1. Remove cables from the CMA.
2. For CMA connector #4, pull the metal release tab toward the center of the rack and slide the connector toward the rear to release it.
3. For CMA connectors #3, #2, and #1, depress the front edge of the yellow plastic rocker lock and slide the connector toward the rear to release it.

## 6.5 TPM Security Module

SPI capable TPM 2.0 (or 1.2) with Infineon 9670 controller, vertical form factor

The JTPM1 header is used to connect a Trusted Platform Module (TPM). A TPM is a security device that supports encryption and authentication in hard drives. It enables the motherboard to deny access if the TPM associated with the hard drive is not installed in the system.

Details and installation procedures are at:

<http://www.supermicro.com/manuals/other/TPM.pdf>.

- AOM-TPM-9670V

## Chapter 7

# Troubleshooting and Support

## 7.1 Information Resources

### Website

A great deal of information is available on the Supermicro website, [supermicro.com](http://supermicro.com).

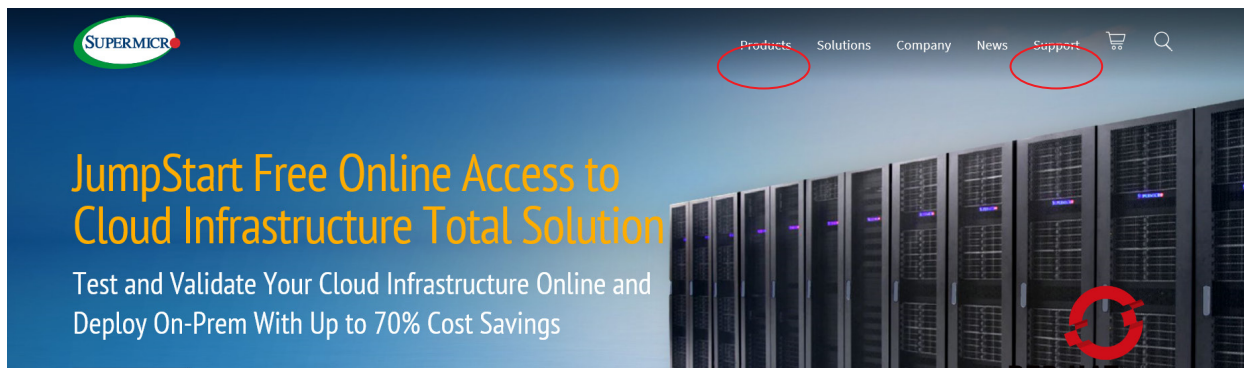

Figure 7-1. Supermicro Website

- Specifications for servers and other hardware are available by the **Products** option.
- The **Support** option offers downloads (manuals, BIOS/BMC, drivers, etc.), FAQs, RMA, warranty, and other service extensions.

### *Direct Links for the AS -1125HS-TNR System*

Web [AS -1125HS-TNR](#) specifications page

[H13DSH](#) motherboard page for links to the Quick Reference Guide, User Manual, validated storage drives, etc.

### *Direct Links for General Support and Information*

[Frequently Asked Questions](#)

[Add-on card descriptions](#)

[TPM User Guide](#)

[BMC User Guide](#)

[SuperDoctor5 Large Deployment Guide](#)

For validated memory, use our [Product Resources](#) page

## Direct Links (continued)

[Product Matrices](#) page for links to tables summarizing specs for systems, motherboards, power supplies, riser cards, add-on cards, etc.

[Security Center](#) for recent security notices

[Supermicro Phone and Addresses](#)

## 7.2 Baseboard Management Controller (BMC)

The system supports the Baseboard Management Controller (BMC). BMC is used to provide remote access, monitoring and management. There are several BIOS settings that are related to BMC.

For general documentation and information on BMC, please visit our website at: [https://www.supermicro.com/manuals/other/BMC\\_IPMI\\_X13\\_H13.pdf](https://www.supermicro.com/manuals/other/BMC_IPMI_X13_H13.pdf)

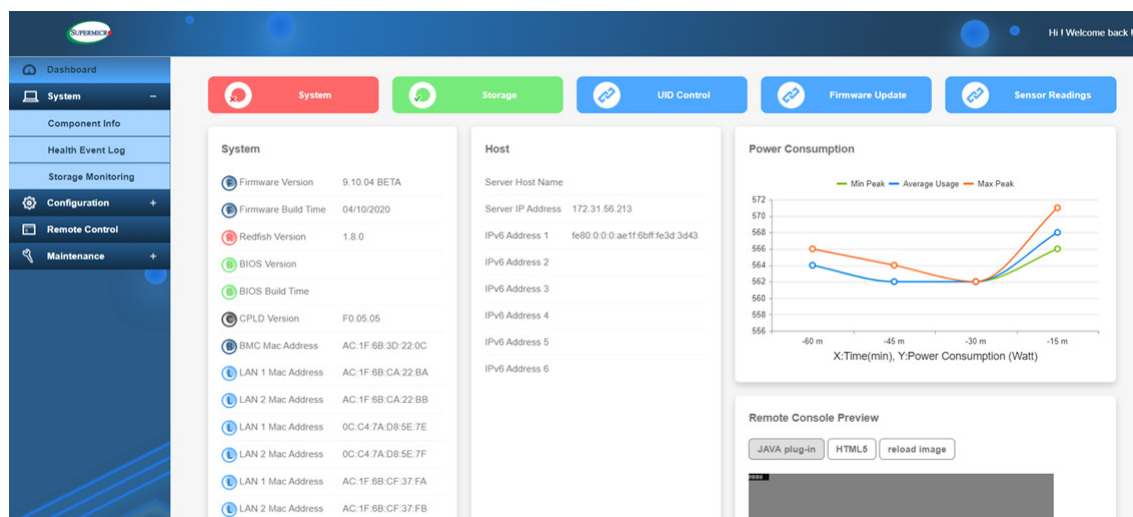

Figure 7-2. BMC Sample

## 7.3 Troubleshooting Procedures

Use the following procedures to troubleshoot your system. If you have followed all of the procedures below and still need assistance, refer to the 'Technical Support Procedures' and/or 'Returning Merchandise for Service' section(s) in this chapter. Always disconnect the AC power cord before adding, changing or installing any non hot-swap hardware components.

### Before Power On

1. Check that the BMC\_HB LED is blinking before the motherboard is turned on.
2. Check that the PWROK LED on the motherboard is on.
3. Make sure that the power connector is connected to your power supply.
4. Make sure that no short circuits exist between the motherboard and chassis.
5. Disconnect all cables from the motherboard, including those for the keyboard and mouse.
6. Remove all add-on cards.
7. Install a CPU, a heatsink\*, and at least one DIMM on the motherboard. Check all jumper settings properly. \*Make sure that the heatsink is fully seated.
8. Use the correct type of onboard CMOS battery (CR2032) as recommended by the manufacturer. To avoid possible explosion, do not install the CMOS battery upside down.

### No Power

1. Make sure that no short circuits exist between the motherboard and the chassis.
2. Verify that all jumpers are set to their default positions.
3. Check that the 115 V/230 V switch on the power supply is properly set.
4. Turn the power switch on and off to test the system
5. The CMOS battery on your motherboard may be old. Check to verify that it still supplies approximately 3 VDC. If it does not, replace it with a new one.

### No Video

1. Check that the VGA cable is connected properly, and the monitor is on.

2. Check if you followed the guidelines to install the memory module (see Section 3.4).
3. Reseat the memory DIMM module.

**Note:** If you are a system integrator, VAR or OEM, a POST diagnostics card is recommended.

## System Boot Failure

If the system does not display POST (Power-On-Self-Test) or does not respond after the power is turned on, check the following:

1. Clear the CMOS settings by unplugging the power cord and contacting both pads on the CMOS Clear Jumper (JBT1). Refer to Section 7.6.
2. Remove all components from the motherboard, especially the DIMM modules.
3. Turn on the system with only one DIMM module installed. If the system boots, check for bad DIMM modules or slots by following the Memory Errors Troubleshooting procedure in this Chapter.

## Memory Errors

1. Make sure that the DIMM modules are properly and fully installed.
2. Confirm that you are using the correct memory. Also, it is recommended that you use the same memory type and speed for all DIMMs in the system. See Section 3.4 for memory details.
3. Check for bad DIMM modules or slots by swapping modules between slots and noting the results.
4. Check the power supply voltage 115 V/230 V switch.

## The System Cannot Retain the Setup Configuration

1. Make sure that you are using a high quality power supply. A poor quality power supply may cause the system to lose the CMOS setup information. Refer to Section 6.3 for details on power supplies.
2. The battery on your motherboard may be old. Check to verify that it still supplies approximately 3VDC. If it does not, replace it with a new one.
3. If the above steps do not fix the setup configuration problem, contact your vendor for repairs.

## When the System Becomes Unstable

### **A. If the system becomes unstable during or after OS installation, check the following:**

1. CPU/BIOS support: Make sure that your CPU is supported and that you have the latest BIOS installed in your system.
2. Memory support: Make sure that the memory modules are supported by testing the modules using memtest86 or a similar utility.

**Note:** Refer to the product page on our website at <http://www.supermicro.com> for memory and CPU support and updates.

3. HDD support: Make sure that all hard disk drives (HDDs) work properly. Replace the bad HDDs with good ones.
4. System cooling: Check the system cooling to make sure that all heatsink fans and CPU/system fans, etc., work properly. Check the hardware monitoring settings in the IPMI to make sure that the CPU and system temperatures are within the normal range. Also check the front panel Overheat LED and make sure that it is not on.
5. Adequate power supply: Make sure that the power supply provides adequate power to the system. Make sure that all power connectors are connected. Please refer to our website for more information on the minimum power requirements.
6. Proper software support: Make sure that the correct drivers are used.

### **B. If the system becomes unstable before or during OS installation, check the following:**

1. Source of installation: Make sure that the devices used for installation are working properly, including boot devices such as USB flash or media drives.
2. Cable connection: Check to make sure that all cables are connected and working properly.
3. Using the minimum configuration for troubleshooting: Remove all unnecessary components (starting with add-on cards first), and use the minimum configuration (but with a CPU and a memory module installed) to identify the trouble areas. Refer to the steps listed in Section A above for proper troubleshooting procedures.
4. Identifying bad components by isolating them: If necessary, remove a component in question from the chassis, and test it in isolation to make sure that it works properly. Replace a bad component with a good one.

## 7.4 Crash Dump Using BMC

In the event of a processor internal error (IERR) that crashes your system, you may want to provide information to support staff. You can download a crash dump of status information using BMC. The BMC manual is available at [https://www.supermicro.com/manuals/other/BMC\\_IPMI\\_X13\\_H13.pdf](https://www.supermicro.com/manuals/other/BMC_IPMI_X13_H13.pdf).

### Check BMC Error Log

1. Access the BMC web interface.
2. Click the **Server Health** tab, then **Event Log** to verify an IERR error.

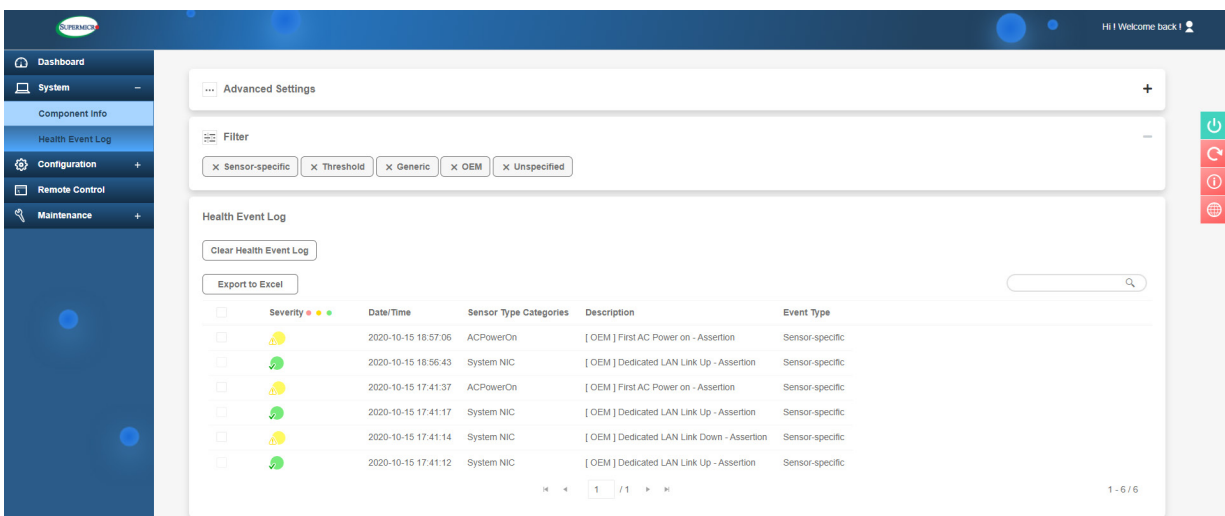

Figure 7-3. BMC Event Log

In the event of an IERR, the BMC executes a crash dump. You must download the crash dump and save it.

## 7.5 UEFI BIOS Recovery

**Warning:** Do not upgrade the BIOS unless your system has a BIOS-related issue. Flashing the wrong BIOS can cause irreparable damage to the system. In no event shall Supermicro be liable for direct, indirect, special, incidental, or consequential damages arising from a BIOS update. If you do update the BIOS, do not shut down or reset the system while the BIOS is updating to avoid possible boot failure.

### Overview

The Unified Extensible Firmware Interface (UEFI) provides a software-based interface between the operating system and the platform firmware in the pre-boot environment. The UEFI specification supports an architecture-independent mechanism that will allow the UEFI OS loader stored in an add-on card to boot the system. The UEFI offers clean, hands-off management to a computer during system boot.

### Recovering the UEFI BIOS Image

A UEFI BIOS flash chip consists of a recovery BIOS block and a main BIOS block (a main BIOS image). The recovery block contains critical BIOS codes, including memory detection and recovery codes for the user to flash a healthy BIOS image if the original main BIOS image is corrupted. When the system power is turned on, the recovery block codes execute first. Once this process is complete, the main BIOS code will continue with system initialization and the remaining POST (Power-On Self-Test) routines.

**Note 1:** Follow the BIOS recovery instructions below for BIOS recovery when the main BIOS block crashes.

**Note 2:** When the BIOS recovery block crashes, you will need to follow the procedures to make a Returned Merchandise Authorization (RMA) request. Also, you may use the Supermicro Update Manager (SUM) Out-of-Band ([https://www.supermicro.com.tw/products/nfo/SMS\\_SUM.cfm](https://www.supermicro.com.tw/products/nfo/SMS_SUM.cfm)) to reflash the BIOS.

### Recovering the Main BIOS Block with a USB Device

This feature allows the user to recover the main BIOS image using a USB-attached device without additional utilities used. A USB flash device device can be used for this purpose. However, a USB Hard Disk drive cannot be used for BIOS recovery at this time.

The file system supported by the recovery block is FAT (including FAT12, FAT16, and FAT32) which is installed on a bootable or non-bootable USB-attached device. However, the BIOS might need several minutes to locate the SUPER.ROM file if the media size becomes too large due to the huge volumes of folders and files stored in the device.

To perform UEFI BIOS recovery using a USB-attached device, follow the instructions below.

1. Using a different machine, copy the "Super.ROM" binary image file into the Root "\\" directory of a USB flash or media drive.

**Note 1:** If you cannot locate the "Super.ROM" file in your drive disk, visit our website at [www.supermicro.com](http://www.supermicro.com) to download the BIOS package. Extract the BIOS binary image into a USB flash device and rename it "Super.ROM" for the BIOS recovery use.

**Note 2:** Before recovering the main BIOS image, confirm that the "Super.ROM" binary image file you download is the same version or a close version meant for your motherboard.

2. Insert the USB device that contains the new BIOS image ("Super.ROM") into your USB drive and reset the system when the following screen appears.
3. After locating the healthy BIOS binary image, the system will enter the BIOS Recovery menu as shown below.



**Note:** At this point, you may decide if you want to start the BIOS recovery. If you decide to proceed with BIOS recovery, follow the procedures below.

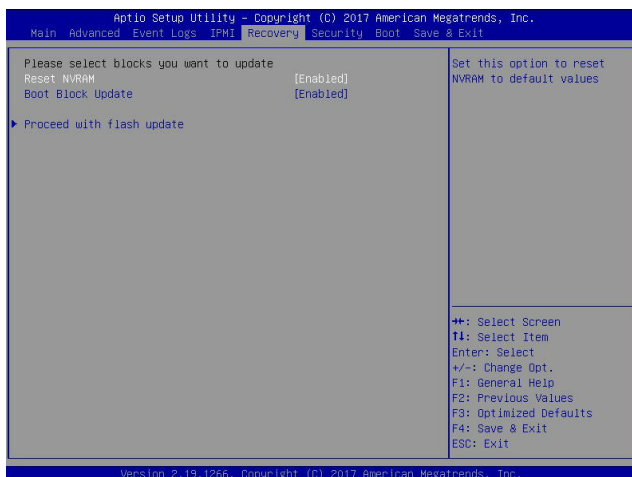

4. When the screen as shown above displays, use the arrow keys to select the item "Proceed with flash update" and press the <Enter> key. You will see the BIOS recovery progress as shown in the screen below.

**Note:** *Do not interrupt the BIOS flashing process until it has completed.*

5. After the BIOS recovery process is complete, press any key to reboot the system.
6. Using a different system, extract the BIOS package into a USB flash drive.

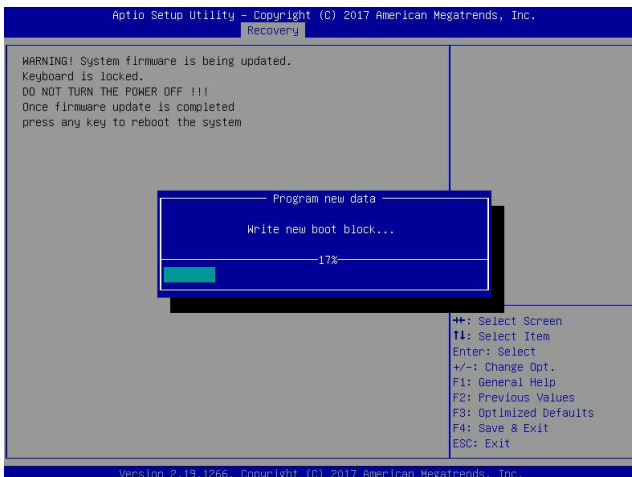

7. Press <Del> continuously during system boot to enter the BIOS Setup utility. From the top of the tool bar, select Boot to enter the submenu. From the submenu list, select Boot

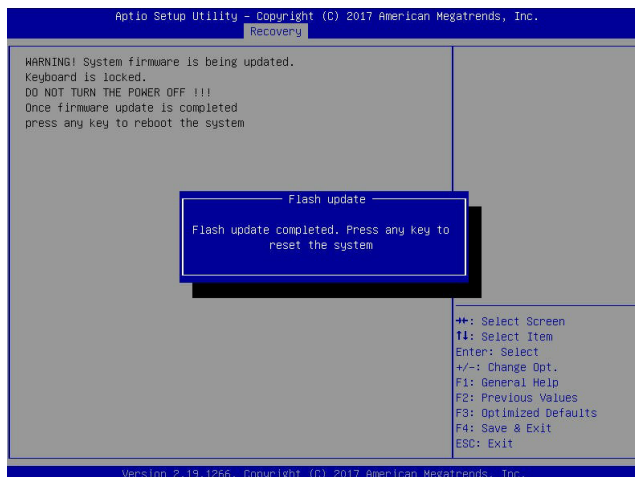

Option #1 as shown below. Then, set Boot Option #1 to [UEFI AP:UEFI: Built-in EFI Shell]. Press <F4> to save the settings and exit the BIOS Setup utility.

8. When the UEFI Shell prompt appears, type fs# to change the device directory path. Go to the directory that contains the BIOS package you extracted earlier from Step 6. Enter flash.nsh BIOSname.### at the prompt to start the BIOS update process.

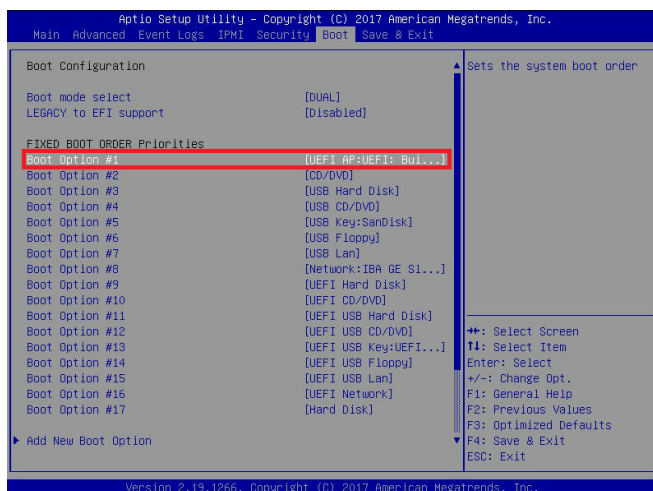

**Note:** Do not interrupt this process until the BIOS flashing is complete.

```

UEFI Interactive Shell v2.1
EDK II
UEFI v2.50 (American Megatrends, 0x0005000C)
Mapping table
  FS0: Alias(s):HD0:0:0:BLK1:
        PciRoot(0x0)/Pci(0x14,0x0)/USB(0x11,0x0)/HD(1,MBR,0x37901D72,0x800,0x1
CR9592)
  BLK0: Alias(s):
        PciRoot(0x0)/Pci(0x14,0x0)/USB(0x11,0x0)
Press F8 in 1 seconds to skip startup.nsh or any other key to continue.
Shell: fs0:
FS0:\> cd \AFUDOS
FS0:\AFUDOS> cd SNIJPM2_03162017
FS0:\AFUDOS\SNIJPM2_03162017> flash.nsh X110PU7_314

```

9. The screen above indicates that the BIOS update process is complete. When you see the screen above, unplug the AC power cable from the power supply, clear CMOS, and plug

```

Done.
[ Access Cmos Port Ex ]
<Read>
Index 0x51: 0x10

Done.
*****
*
* Program BIOS and ME (including FDT) regions...
*
*****
| AMT Firmware Update Utility v5.09.01.1917 |
| Copyright (C)2017 American Megatrends Inc. All Rights Reserved. |
*****
CPUID = 50652

Reading flash ..... done
- ME Data Size checking - ok
- FFS checksums ..... ok
- Check RomLayout ..... Ok
Erasing Boot Block ..... done
Updating Boot Block ..... done
Verifying Boot Block ..... done
_Erasing Main Block ..... 0x00132000 (0x)

```

the AC power cable in the power supply again to power on the system.

10. Press <Del> continuously to enter the BIOS Setup utility.

```

Verifying NDB Block ..... done
- Update success for FDR
- Update success for IE
- Successful Update Recovery Loader to OPR!!
- Successful Update MFSBI!
- Successful Update FPR!!
- Successful Update MFS, IVBI and IVB2!!
- Successful Update FLOG and UTDK!!
- ME Entire Image update success !!
WARNING : System must power-off to have the changes take effect!
Moving FS0:\AFUDOS\SNIJPM2_03162017\Fdtv64.efi -> FS0:\AFUDOS\SNIJPM2_03162017\
d1.smc
- [ok]
Moving FS0:\AFUDOS\SNIJPM2_03162017\afuef1x64.efi -> FS0:\AFUDOS\SNIJPM2_0316201
7\afuef1.smc
- [ok]
*****
* Please ignore this 'Shell: Cannot read from file - Device Error'
* warning message due to it does not impact flashing process.
*
*****
Deleting "afuef1.smc"
Delete successful.
FS0:\>

```

11. Press <F3> to load the default settings.

12. After loading the default settings, press <F4> to save the settings and exit the BIOS Setup utility.

## 7.6 CMOS Clear

JBT1 is used to clear CMOS, which will also clear any passwords. Instead of pins, this jumper consists of contact pads to prevent accidentally clearing the contents of CMOS.

### **To Clear CMOS**

1. First [power down](#) the system completely.
2. [Remove chassis cover](#) to access the motherboard.
3. [Remove the onboard battery](#) from the motherboard.
4. Short the CMOS pads with a metal object such as a small screwdriver for at least four seconds.
5. Remove the screwdriver or shorting device.
6. Re-install the battery.
7. Replace the cover, reconnect the power cords and power on the system.

**Notes:** Clearing CMOS will also clear all passwords.

*Do not use the PW\_ON connector to clear CMOS.*



JBT1 contact pads

## 7.7 Where to Get Replacement Components

If you need replacement parts for your system, to ensure the highest level of professional service and technical support, purchase exclusively from our Supermicro Authorized Distributors/System Integrators/Resellers. A list can be found at: <http://www.supermicro.com>. Click the "Where to Buy" tab.

## 7.8 BMC

The BMC can be reset using the button on the front control panel or on the chassis rear.

- Reset—Press and hold the button. After six seconds, the LED blinks at 2 Hz. The BMC resets and the reset duration is approximately 250 ms. Then the BMC starts to boot.
- Restore factory default configuration—Hold the button for twelve seconds. The LED blinks at 4 Hz while defaults are configured.
- Firmware update—the UID LED blinks at 10 Hz during a firmware update.

BMC Reset Options	
Event	LED (Green)
Reset	Blinks at 2 Hz
Restore Defaults	Blinks at 4 Hz
Update	Blinks at 10 Hz

## 7.9 Reporting an Issue

### Technical Support Procedures

Before contacting Technical Support, please take the following steps. If your system was purchased through a distributor or reseller, please contact them for troubleshooting services. They have the best knowledge of your specific system configuration.

1. Please review the [Troubleshooting Procedures](#) in this manual and [Frequently Asked Questions](#) on our website before contacting Technical Support.
2. BIOS upgrades can be downloaded from our website. **Note:** Not all BIOS can be flashed depending on the modifications to the boot block code.
3. If you still cannot resolve the problem, include the following information when contacting us for technical support:
  - System, motherboard, and chassis model numbers and PCB revision number
  - BIOS release date/version (this can be seen on the initial display when your system first boots up)
  - System configuration

An example of a Technical Support form is posted on our [website](#). Distributors: For immediate assistance, please have your account number ready when contacting our technical support department by email.

### Returning Merchandise for Service

A receipt or copy of your invoice marked with the date of purchase is required before any warranty service will be rendered. You can obtain service by calling your vendor for a Returned Merchandise Authorization (RMA) number. When returning to the manufacturer, the RMA number should be prominently displayed on the outside of the shipping carton, and mailed prepaid or hand-carried. Shipping and handling charges will be applied for all orders that must be mailed when service is complete.

For faster service, RMA authorizations may be requested online (<http://www.supermicro.com/support/rma/>).

Whenever possible, repack the chassis in the original Supermicro carton, using the original packaging material. If these are no longer available, be sure to pack the chassis securely, using packaging material to surround the chassis so that it does not shift within the carton and become damaged during shipping.

This warranty only covers normal consumer use and does not cover damages incurred in shipping or from failure due to the alteration, misuse, abuse or improper maintenance of products.

During the warranty period, contact your distributor first for any product problems.

## 7.10 Feedback

Supernano values your feedback as we strive to improve our customer experience in all facets of our business. Please email us at [techwriterteam@supernano.com](mailto:techwriterteam@supernano.com) to provide feedback on our manuals.

## Appendix A

# Standardized Warning Statements for AC Systems

### About Standardized Warning Statements

The following statements are industry standard warnings, provided to warn the user of situations which have the potential for bodily injury. Should you have questions or experience difficulty, contact Supermicro's Technical Support department for assistance. Only certified technicians should attempt to install or configure components.

Read this appendix in its entirety before installing or configuring components in the Supermicro chassis.

These warnings may also be found on our website at [http://www.supermicro.com/about/policies/safety\\_information.cfm](http://www.supermicro.com/about/policies/safety_information.cfm).

### Warning Definition



**Warning!** This warning symbol means danger. You are in a situation that could cause bodily injury. Before you work on any equipment, be aware of the hazards involved with electrical circuitry and be familiar with standard practices for preventing accidents.

#### 警告の定義

この警告サインは危険を意味します。

人身事故につながる可能性がありますので、いずれの機器でも動作させる前に、電気回路に含まれる危険性に注意して、標準的な事故防止策に精通して下さい。

此警告符号代表危險。

您正处于可能受到严重伤害的工作环境中。在您使用设备开始工作之前，必须充分意识到触电的危险，并熟练掌握防止事故发生的标准工作程序。请根据每项警告结尾的声明号码找到此设备的安全性警告说明的翻译文本。

此警告符號代表危險。

您正處於可能身體可能會受損傷的工作環境中。在您使用任何設備之前，請注意觸電的危險，並且要熟悉預防事故發生的標準工作程序。請依照每一注意事項後的號碼找到相關的翻譯說明內容。

## Warnung

### WICHTIGE SICHERHEITSHINWEISE

Dieses Warnsymbol bedeutet Gefahr. Sie befinden sich in einer Situation, die zu Verletzungen führen kann. Machen Sie sich vor der Arbeit mit Geräten mit den Gefahren elektrischer Schaltungen und den üblichen Verfahren zur Vorbeugung vor Unfällen vertraut. Suchen Sie mit der am Ende jeder Warnung angegebenen Anweisungsnummer nach der jeweiligen Übersetzung in den übersetzten Sicherheitshinweisen, die zusammen mit diesem Gerät ausgeliefert wurden.

BEWAHREN SIE DIESE HINWEISE GUT AUF.

### INSTRUCCIONES IMPORTANTES DE SEGURIDAD

Este símbolo de aviso indica peligro. Existe riesgo para su integridad física. Antes de manipular cualquier equipo, considere los riesgos de la corriente eléctrica y familiarícese con los procedimientos estándar de prevención de accidentes. Al final de cada advertencia encontrará el número que le ayudará a encontrar el texto traducido en el apartado de traducciones que acompaña a este dispositivo.

GUARDE ESTAS INSTRUCCIONES.

### IMPORTANTES INFORMATIONS DE SÉCURITÉ

Ce symbole d'avertissement indique un danger. Vous vous trouvez dans une situation pouvant entraîner des blessures ou des dommages corporels. Avant de travailler sur un équipement, soyez conscient des dangers liés aux circuits électriques et familiarisez-vous avec les procédures couramment utilisées pour éviter les accidents. Pour prendre connaissance des traductions des avertissements figurant dans les consignes de sécurité traduites qui accompagnent cet appareil, référez-vous au numéro de l'instruction situé à la fin de chaque avertissement.

CONSERVEZ CES INFORMATIONS.

## תקנון הזהרות אזהרה

הזהרות הבאות הן אזהרות על פי תקני התעשייה, על מנת להזהיר את המשתמש מפני חבלה פיזית אפשרית. במידה ויש שאלות או היתקלות בבעיה כלשהי, יש ליצור קשר עם מחלקת תמיכה טכנית של סופרמיקרו. טכנאים מוסמכים בלבד רשאים להתקין או להגדיר את הרכיבים. יש לקרוא את הנספח במלואו לפני התקנת או הגדרת הרכיבים במארזי סופרמיקרו.

اَكْ ف حالة وُكِي اَي تتسبب ف اصابة جسدهُ هذا الزهز عْ خطر! تحذُرُ .  
 قبل اَي تعول على اَي هعدات، كي على علن بالوخاطز ال اَجوة عي الذوائر  
 الكهزبائِة  
 وكي على دراةُ بالووارسات النقاىِة لو عْ وقع اَي حادث  
 استخدم رقن الب اى الو صُص ف هاةُ كل تحذُرُ للعشر تزجوتها

안전을 위한 주의사항

경고!

이 경고 기호는 위험이 있음을 알려 줍니다. 작업자의 신체에 부상을 야기 할 수 있는 상태에 있게 됩니다. 모든 장비에 대한 작업을 수행하기 전에 전기회로와 관련된 위험요소들을 확인하시고 사전에 사고를 방지할 수 있도록 표준 작업절차를 준수해 주시기 바랍니다.

해당 번역문을 찾기 위해 각 경고의 마지막 부분에 제공된 경고문 번호를 참조하십시오

## BELANGRIJKE VEILIGHEIDSINSTRUCTIES

Dit waarschuwings symbool betekent gevaar. U verkeert in een situatie die lichamelijk letsel kan veroorzaken. Voordat u aan enige apparatuur gaat werken, dient u zich bewust te zijn van de bij een elektrische installatie betrokken risico's en dient u op de hoogte te zijn van de standaard procedures om ongelukken te voorkomen. Gebruik de nummers aan het eind van elke waarschuwing om deze te herleiden naar de desbetreffende locatie.

BEWAAR DEZE INSTRUCTIES

## Installation Instructions



**Warning!** Read the installation instructions before connecting the system to the power source.

設置手順書

システムを電源に接続する前に、設置手順書をお読み下さい。

警告

将此系统连接电源前,请先阅读安装说明。

警告

將系統與電源連接前，請先閱讀安裝說明。

**Warnung**

Vor dem Anschließen des Systems an die Stromquelle die Installationsanweisungen lesen.

**¡Advertencia!**

Lea las instrucciones de instalación antes de conectar el sistema a la red de alimentación.

**Attention**

Avant de brancher le système sur la source d'alimentation, consulter les directives d'installation.

יש לקרוא את הוראות התקנה לפני חיבור המערכת למקור מתח.

اقرأ إرشادات التركيب قبل توصيل النظام إلى مصدر للطاقة

시스템을 전원에 연결하기 전에 설치 안내를 읽어주십시오.

**Waarschuwing**

Raadpleeg de installatie-instructies voordat u het systeem op de voedingsbron aansluit.

**Circuit Breaker**

**Warning!** This product relies on the building's installation for short-circuit (overcurrent) protection. Ensure that the protective device is rated not greater than: 250 V, 20 A.

**サーキット・ブレーカー**

この製品は、短絡(過電流)保護装置がある建物での設置を前提としています。

保護装置の定格が250 V、20 Aを超えないことを確認下さい。

**警告**

此产品的短路(过载电流)保护由建筑物的供电系统提供,确保短路保护设备的额定电流不大于250V,20A。

**警告**

此產品的短路(過載電流)保護由建築物的供電系統提供,確保短路保護設備的額定電流不大於250V,20A。

**Warnung**

Dieses Produkt ist darauf angewiesen, dass im Gebäude ein Kurzschluss- bzw. Überstromschutz installiert ist. Stellen Sie sicher, dass der Nennwert der Schutzvorrichtung nicht mehr als: 250 V, 20 A beträgt.

**¡Advertencia!**

Este equipo utiliza el sistema de protección contra cortocircuitos (o sobrecorrientes) del edificio. Asegúrese de que el dispositivo de protección no sea superior a: 250 V, 20 A.

**Attention**

Pour ce qui est de la protection contre les courts-circuits (surtension), ce produit dépend de l'installation électrique du local. Vérifiez que le courant nominal du dispositif de protection n'est pas supérieur à :250 V, 20 A.

מוצר זה מסתמך על הגנה המותקנת במבנים למניעת קצר חשמלי. יש לוודא כי המכשיר המגן מפני הקצר החשמלי הוא לא יותר מ-250VDC, 20A

هذا المنتج يعتمد على معدات الحماية مه الدوائر القصيرة التي تم تثبيتها في المبنى  
تأكد من أن تقييم الجهاز الوقائي ليس أكثر من : 20A, 250V

**경고!**

이 제품은 전원의 단락(과전류)방지에 대해서 전적으로 건물의 관련 설비에 의존합니다. 보호장치의 정격이 반드시 250V(볼트), 20A(암페어)를 초과하지 않도록 해야 합니다.

**Waarschuwing**

Dit product is afhankelijk van de kortsluitbeveiliging (overspanning) van uw elektrische installatie. Controleer of het beveiligde apparaat niet groter gedimensioneerd is dan 250V, 20A.

## Power Disconnection Warning



**Warning!** The system must be disconnected from all sources of power and the power cord removed from the power supply module(s) before accessing the chassis interior to install or remove system components (except for hot-swap components).



### 電源切断の警告

システムコンポーネントの取り付けまたは取り外しのために、シャーシ内部にアクセスするには、システムの電源はすべてのソースから切断され、電源コードは電源モジュールから取り外す必要があります。

### 警告

在你打开机箱并安装或移除内部器件前,必须将系统完全断电,并移除电源线。

### 警告

在您打開機殼安裝或移除內部元件前，必須將系統完全斷電，並移除電源線。

### Warnung

Das System muss von allen Quellen der Energie und vom Netzanschlusskabel getrennt sein, das von den Spg.Versorgungsteilmodulen entfernt wird, bevor es auf den Chassisinnenraum zurückgreift, um Systemsbestandteile anzubringen oder zu entfernen.

### ¡Advertencia!

El sistema debe ser disconnected de todas las fuentes de energía y del cable eléctrico quitado de los módulos de fuente de alimentación antes de tener acceso el interior del chasis para instalar o para quitar componentes de sistema.

### Attention

Le système doit être débranché de toutes les sources de puissance ainsi que de son cordon d'alimentation secteur avant d'accéder à l'intérieur du chasis pour installer ou enlever des composants de système.

אזהרה מפני ניתוק חשמלי

אזהרה!

יש לנתק את המערכת מכל מקורות החשמל ויש להסיר את כבל החשמלי מהספק לפני גישה לחלק הפנימי של המארז לצורך התקנת או הסרת רכיבים.

يجب فصل انظاؤ من جميع مصادر انطاقت وإزانت سهك انكهرباء من وحدة امداد انطاقت قيم

انصل إلى امناطق انداخييت نههيكم نشييج أو إزانت مكنناث الجهاز

경고!

시스템에 부품들을 장착하거나 제거하기 위해서는 새시 내부에 접근하기 전에 반드시 전원 공급장치로부터 연결되어있는 모든 전원과 전기코드를 분리해주어야 합니다.

Waarschuwing

Voordat u toegang neemt tot het binnenwerk van de behuizing voor het installeren of verwijderen van systeem onderdelen, dient u alle spanningsbronnen en alle stroomkabels aangesloten op de voeding(en) van de behuizing te verwijderen

## Equipment Installation



**Warning!** Only authorized personnel and qualified service persons should be allowed to install, replace, or service this equipment.

機器の設置

トレーニングを受け認定された人だけがこの装置の設置、交換、またはサービスを許可されています。

警告

只有经过培训且具有资格的人员才能进行此设备的安装、更换和维修。

警告

只有經過受訓且具資格人員才可安裝、更換與維修此設備。

Warnung

Nur autorisiertes Personal und qualifizierte Servicetechniker dürfen dieses Gerät installieren, austauschen oder warten..

¡Advertencia!

Sólo el personal autorizado y el personal de servicio calificado deben poder instalar, reemplazar o dar servicio a este equipo.

**Attention**

Seul le personnel autorisé et le personnel de maintenance qualifié doivent être autorisés à installer, remplacer ou entretenir cet équipement..

אזהרה!

יש לאפשר רק צוות מורשה ואנשי שירות מוסמכים להתקין, להחליף או לטפל בציוד זה.

ينبغي السماح فقط للموظفين المعتمدين وأفراد الخدمة المؤهلين بتركيب هذا الجهاز أو استبداله أو صيانته.

**경고!**

승인된 직원과 자격을 갖춘 서비스 담당자만이 이 장비를 설치, 교체 또는 서비스할 수 있습니다.

**Waarschuwing**

Alleen geautoriseerd personeel en gekwalificeerd onderhoudspersoneel mag deze apparatuur installeren, vervangen of onderhouden..

**Restricted Area**

**Warning!** This unit is intended for installation in restricted access areas. A restricted access area can be accessed only through the use of a special tool, lock and key, or other means of security. (This warning does not apply to workstations).

**アクセス制限区域**

このユニットは、アクセス制限区域に設置されることを想定しています。

アクセス制限区域は、特別なツール、鍵と錠前、その他のセキュリティの手段を用いてのみ出入りが可能です。

**警告**

此部件应安装在限制进出的场所，限制进出的场所指只能通过使用特殊工具、锁和钥匙或其它安全手段进出的场所。

**警告**

此裝置僅限安裝於進出管制區域，進出管制區域係指僅能以特殊工具、鎖頭及鑰匙或其他安全方式才能進入的區域。

**Warnung**

Diese Einheit ist zur Installation in Bereichen mit beschränktem Zutritt vorgesehen. Der Zutritt zu derartigen Bereichen ist nur mit einem Spezialwerkzeug, Schloss und Schlüssel oder einer sonstigen Sicherheitsvorkehrung möglich.

**¡Advertencia!**

Esta unidad ha sido diseñada para instalación en áreas de acceso restringido. Sólo puede obtenerse acceso a una de estas áreas mediante la utilización de una herramienta especial, cerradura con llave u otro medio de seguridad.

**Attention**

Cet appareil doit être installée dans des zones d'accès réservés. L'accès à une zone d'accès réservé n'est possible qu'en utilisant un outil spécial, un mécanisme de verrouillage et une clé, ou tout autre moyen de sécurité.

אזור עם גישה מוגבלת

אזהרה!

יש להתקין את היחידה באזורים שיש בהם הגבלת גישה. הגישה ניתנת בעזרת 'כלי אבטחה בלבד' (מפתח, מנעול וכד.).

تخصيص هذه انحدة نترك بُها ف مناطق محظورة تم .

،ممكن اننصل إن منطقت محظورة فقط من خلال استخذاو أداة خاصت أو أ وس هُت أخري نلالأمما ققم ومفتاح

**경고!**

이 장치는 접근이 제한된 구역에 설치하도록 되어있습니다. 특수도구, 잠금 장치 및 키, 또는 기타 보안 수단을 통해서만 접근 제한 구역에 들어갈 수 있습니다.

**Waarschuwing**

Dit apparaat is bedoeld voor installatie in gebieden met een beperkte toegang. Toegang tot dergelijke gebieden kunnen alleen verkregen worden door gebruik te maken van speciaal gereedschap, slot en sleutel of andere veiligheidsmaatregelen.

## Battery Handling



**CAUTION:** There is risk of explosion if the battery is replaced by an incorrect type. Replace the battery only with the same or equivalent type recommended by the manufacturer. Dispose of used batteries according to the manufacturer's instructions

### 電池の取り扱い

バッテリーを間違ったタイプに交換すると爆発の危険があります。交換する電池はメーカーが推奨する型、または同等のものを使用下さい。使用済電池は製造元の指示に従って処分して下さい。

### 警告

如果更换的电池类型不正确，则存在爆炸危险。请只使用同类电池或制造商推荐的功能相当的电池更换原有电池。请按制造商的说明处理废旧电池。

### 警告

如果更換的電池類型不正確，則有爆炸危險。請使用製造商建議之相同或功能相當的電池更換原有電池。請按照製造商的說明指示處理廢棄舊電池。

### WARNUNG

Es besteht Explosionsgefahr, wenn die Batterie durch einen falschen Typ ersetzt wird. Ersetzen Sie die Batterie nur durch den gleichen oder vom Hersteller empfohlenen Batterietyp. Entsorgen Sie die benutzten Batterien nach den Anweisungen des Herstellers.

### ATTENTION

Il existe un risque d'explosion si la batterie est remplacée par un type incorrect. Ne la remplacer que par une pile de type semblable ou équivalent, recommandée par le fabricant. Jeter les piles usagées conformément aux instructions du fabricant.

### ADVERTENCIA

Existe riesgo de explosión si la batería se reemplaza por un tipo incorrecto. Reemplazar la batería exclusivamente con el mismo tipo o el equivalente recomendado por el fabricante. Desechar las baterías gastadas según las instrucciones del fabricante.

אזהרה!

קיימת סכנת פיצוץ אם הסוללה תוחלף בסוג שגוי. יש להחליף את הסוללה בסוג התואם מחברת יצרן מומלצת. סילוק הסוללות המשומשות יש לבצע לפי הוראות היצרן.

هناك خطر الانفجار إذا تم استبدال البطارية بنوع غير صحيح.  
 اسحبذال البطارية  
 فقط بنفس النوع أو ما يعادلها مما أوصت به الشركة المصنعة  
 جخلص من البطاريات المسحمة وفقا لعمليات الشركة الصانعة

경고!

배터리를 잘못된 종류로 교체하면 폭발의 위험이 있습니다. 기존 배터리와 동일하거나 제조사에서 권장하는 동등한 종류의 배터리로만 교체해야 합니다. 제조사의 안내에 따라 사용된 배터리를 처리하여 주십시오.

#### WAARSCHUWING

Er bestaat explosiegevaar als de batterij wordt vervangen door een verkeerd type. Vervang de batterij slechts met hetzelfde of een equivalent type die door de fabrikant aanbevolen wordt. Gebruikte batterijen dienen overeenkomstig fabrieksvoorschriften afgevoerd te worden.

### Redundant Power Supplies



**Warning!** This unit might have more than one power supply connection. All connections must be removed to de-energize the unit.

冗長電源装置

このユニットは複数の電源装置が接続されている場合があります。

ユニットの電源を切るためには、すべての接続を取り外さなければなりません。

警告

此部件连接的电源可能不止一个，必须将所有电源断开才能停止给该部件供电。

警告

此装置连接的电源可能不只一个，必须切断所有电源才能停止对该装置的供电。

Warnung

Dieses Gerät kann mehr als eine Stromzufuhr haben. Um sicherzustellen, dass der Einheit kein Strom zugeführt wird, müssen alle Verbindungen entfernt werden.

## ¡Advertencia!

Puede que esta unidad tenga más de una conexión para fuentes de alimentación. Para cortar por completo el suministro de energía, deben desconectarse todas las conexiones.

## Attention

Cette unité peut avoir plus d'une connexion d'alimentation. Pour supprimer toute tension et tout courant électrique de l'unité, toutes les connexions d'alimentation doivent être débranchées.

אם קיים יותר מספק אחד

אזהרה!

ליחידה יש יותר מחיבור אחד של ספק. יש להסיר את כל החיבורים על מנת לרוקן את היחידה.

قد يكون لهذا الجهاز عدة اتصالات بوحدات امداد الطاقة .

يجب إزالة كافة الاتصالات لعسل الوحدة عن الكهرباء

## 경고!

이 장치에는 한 개 이상의 전원 공급 단자가 연결되어 있을 수 있습니다. 이 장치에 전원을 차단하기 위해서는 모든 연결 단자를 제거해야만 합니다.

## Waarschuwing

Deze eenheid kan meer dan één stroomtoevoeraansluiting bevatten. Alle aansluitingen dienen verwijderd te worden om het apparaat stroomloos te maken.

## Backplane Voltage



**Warning!** Hazardous voltage or energy is present on the backplane when the system is operating. Use caution when servicing.

バックプレーンの電圧

システムの稼働中は危険な電圧または電力が、バックプレーン上にかかっています。

修理する際には注意ください。

警告

当系统正在进行时，背板上有很危险的电压或能量，进行维修时务必小心。

警告

當系統正在進行時，背板上有危險的電壓或能量，進行維修時務必小心。

Warnung

Wenn das System in Betrieb ist, treten auf der Rückwandplatine gefährliche Spannungen oder Energien auf. Vorsicht bei der Wartung.

¡Advertencia!

Cuando el sistema está en funcionamiento, el voltaje del plano trasero es peligroso. Tenga cuidado cuando lo revise.

Attention

Lorsque le système est en fonctionnement, des tensions électriques circulent sur le fond de panier. Prendre des précautions lors de la maintenance.

מתח בפנל האחורי

אזהרה!

קיימת סכנת מתח בפנל האחורי בזמן תפעול המערכת. יש להיזהר במהלך העבודה.

هناك خطر من التيار الكهربائي أو الطاقة المتجددة على اللوحة  
عندما يكون النظام يعمل كه حذرا عند خدمة هذا الجهاز

경고!

시스템이 동작 중일 때 후면판 (Backplane)에는 위험한 전압이나 에너지가 발생 합니다.  
서비스 작업 시 주의하십시오.

Waarschuwing

Een gevaarlijke spanning of energie is aanwezig op de backplane wanneer het systeem in gebruik is. Voorzichtigheid is geboden tijdens het onderhoud.

## Comply with Local and National Electrical Codes



**Warning!** Installation of the equipment must comply with local and national electrical codes.

地方および国の電気規格に準拠

機器の取り付けはその地方および国の電気規格に準拠する必要があります。

警告

设备安装必须符合本地与本国电气法规。

警告

設備安裝必須符合本地與本國電氣法規。

Warnung

Die Installation der Geräte muss den Sicherheitsstandards entsprechen.

¡Advertencia!

La instalación del equipo debe cumplir con las normas de electricidad locales y nacionales.

Attention

L'équipement doit être installé conformément aux normes électriques nationales et locales.

תיאום חוקי החשמל הארצי  
אזהרה!  
התקנת הציוד חייבת להיות תואמת לחוקי החשמל המקומיים והארציים.

تركيب المعدات الكهربائية يجب أن يمتثل للقوايه المحلية والبطية المتعلقة  
بالكهرباء

경고!

현 지역 및 국가의 전기 규정에 따라 장비를 설치해야 합니다.

Waarschuwing

Bij installatie van de apparatuur moet worden voldaan aan de lokale en nationale elektriciteitsvoorschriften.

## Product Disposal



**Warning!** Ultimate disposal of this product should be handled according to all national laws and regulations.

製品の廃棄

この製品を廃棄処分する場合、国の関係する全ての法律・条例に従い処理する必要があります。

警告

本产品的废弃处理应根据所有国家的法律和规章进行。

警告

本產品的廢棄處理應根據所有國家的法律和規章進行。

Warnung

Die Entsorgung dieses Produkts sollte gemäß allen Bestimmungen und Gesetzen des Landes erfolgen.

¡Advertencia!

Al deshacerse por completo de este producto debe seguir todas las leyes y reglamentos nacionales.

## Attention

La mise au rebut ou le recyclage de ce produit sont généralement soumis à des lois et/ou directives de respect de l'environnement. Renseignez-vous auprès de l'organisme compétent.

סילוק המוצר

אזהרה!

סילוק סופי של מוצר זה חייב להיות בהתאם להנחיות וחוקי המדינה.

التخلص النهائي من هذا المنتج ينبغي التعامل معه وفقا لجميع القوانين واللوائح الوطنية عند

경고!

이 제품은 해당 국가의 관련 법규 및 규정에 따라 폐기되어야 합니다.

## Waarschuwing

De uiteindelijke verwijdering van dit product dient te geschieden in overeenstemming met alle nationale wetten en reglementen.

## Fan Warning



**Warning!** Hazardous moving parts. Keep away from moving fan blades. The fans might still be turning when you remove the fan assembly from the chassis. Keep fingers, screwdrivers, and other objects away from the openings in the fan assembly's housing.

ファンの警告

警告!回転部品に注意。運転中は回転部(羽根)に触れないでください。シャーシから冷却ファン装置を取り外した際、ファンがまだ回転している可能性があります。ファンの開口部に、指、ドライバー、およびその他のものを近づけないで下さい。

警告!

警告! 危險的可移動性零件。請務必與轉動的风扇叶片保持距離。當您從機架移除風扇裝置，風扇可能仍在轉動。小心不要將手指、螺絲起子和其他物品太靠近風扇

警告

危險的可移動性零件。請務必與轉動的风扇叶片保持距離。當您從機架移除風扇裝置，風扇可能仍在轉動。小心不要將手指、螺絲起子和其他物品太靠近風扇。

**Warnung**

Gefährlich Bewegende Teile. Von den bewegenden Lüfterblätter fern halten. Die Lüfter drehen sich u. U. noch, wenn die Lüfterbaugruppe aus dem Chassis genommen wird. Halten Sie Finger, Schraubendreher und andere Gegenstände von den Öffnungen des Lüftergehäuses entfernt.

**¡Advertencia!**

Riesgo de piezas móviles. Mantener alejado de las aspas del ventilador. Los ventiladores podran dar vuelta cuando usted quite el montaje del ventilador del chasis. Mantenga los dedos, los destornilladores y todos los objetos lejos de las aberturas del ventilador

**Attention**

Pieces mobiles dangereuses. Se tenir a l'écart des lames du ventilateur Il est possible que les ventilateurs soient toujours en rotation lorsque vous retirerez le bloc ventilateur du châssis. Prenez garde à ce que doigts, tournevis et autres objets soient éloignés du logement du bloc ventilateur.

**אזהרה!**

חלקים נעים מסוכנים. התרחק מלהבי המאוורר בפעולה כאשר מסירים את חלקי המאוורר מהמארז, יתכן והמאווררים עדיין עובדים. יש להרחיק למרחק בטוח את האצבעות וכלי עבודה שונים מהפתחים בתוך המאוורר

تحذير! أجزاء متحركة خطيرة. ابتعد عن شفرات المروحة المتحركة. من الممكن أن المراوح لا تزال تدور عند إزالة كتلة المروحة من الهيكل يجب إبقاء الأصابع ومفكات البراغي وغيرها من الأشياء بعيدا عن الفتحات في كتلة المروحة

**경고!**

움직이는 위험한 부품. 회전하는 송풍 날개에 접근하지 마세요. 새시로부터 팬 조립품을 제거할 때 팬은 여전히 회전하고 있을 수 있습니다. 팬 조립품 외관의 열려있는 부분들로부터 손가락 및 스크류드라이버, 다른 물체들이 가까이 하지 않도록 배치해 주십시오.

**Waarschuwing**

Gevaarlijk bewegende onderdelen. Houd voldoende afstand tot de bewegende ventilatorbladen. Het is mogelijk dat de ventilator nog draait tijdens het verwijderen van het ventilatorsamenstel uit het chassis. Houd uw vingers, schroevendraaiers en eventuele andere voorwerpen uit de buurt van de openingen in de ventilatorbehuizing.

## Power Cable and AC Adapter



**Warning!** When installing the product, use the provided or designated connection cables, power cables and AC adaptors. Using any other cables and adaptors could cause a malfunction or a fire. Electrical Appliance and Material Safety Law prohibits the use of UL or CSA -certified cables (that have UL/CSA shown on the cord) for any other electrical devices than products designated by Supermicro only.

### 電源コードとACアダプター

製品を設置する場合、提供または指定および購入された接続ケーブル、電源コードとACアダプターを該当する地域の条例や安全基準に適合するコードサイズやプラグと共に使用下さい。他のケーブルやアダプタを使用すると故障や火災の原因になることがあります。

電気用品安全法は、ULまたはCSA認定のケーブル(UL/CSAマークがコードに表記)を Supermicro が指定する製品以外に使用することを禁止しています。

### 警告

安装此产品时,请使用本身提供的或指定的或采购的连接线,电源线和电源适配器。包含遵照当地法规和安全要求的合规的电源线尺寸和插头。使用其它线材或适配器可能会引起故障或火灾。除了Supermicro所指定的产品,电气用品和材料安全法律规定禁止使用未经UL或CSA认证的线材。(线材上会显示UL/CSA符号)。

### 警告

安裝此產品時,請使用本身提供的或指定的或採購的連接線,電源線和電源適配器。包含遵照當地法規和安全要求的合規的電源線尺寸和插頭。使用其它線材或適配器可能會引起故障或火災。除了Supermicro所指定的產品,電氣用品和材料安全法律規定禁止使用未經UL或CSA認證的線材。(線材上會顯示UL/CSA符號)。

### Warnung

Nutzen Sie beim Installieren des Produkts ausschließlich die von uns zur Verfügung gestellten Verbindungskabeln, Stromkabeln und/oder Adapter, die Ihre örtlichen Sicherheitsstandards einhalten. Der Gebrauch von anderen Kabeln und Adapter können Fehlfunktionen oder Feuer verursachen. Die Richtlinien untersagen das Nutzen von UL oder CAS zertifizierten Kabeln (mit UL/CSA gekennzeichnet), an Geräten oder Produkten die nicht mit Supermicro gekennzeichnet sind.



### 전원 케이블 및 AC 어댑터

경고! 제품을 설치할 때 현지 코드 및 적절한 굵기의 코드와 플러그를 포함한 안전 요구 사항을 준수하여 제공되거나 지정된 연결 혹은 구매 케이블, 전원 케이블 및 AC 어댑터를 사용하십시오.

다른 케이블이나 어댑터를 사용하면 오작동이나 화재가 발생할 수 있습니다. 전기 용품 안전법은 UL 또는 CSA 인증 케이블 (코드에 UL / CSA가 표시된 케이블)을 Supermicro 가 지정한 제품 이외의 전기 장치에 사용하는 것을 금지합니다.

### Stroomkabel en AC-Adapter

Waarschuwing! Bij het aansluiten van het Product uitsluitend gebruik maken van de geleverde Kabels of een andere geschikte aan te schaffen Aansluitmethode, deze moet altijd voldoen aan de lokale voorschriften en veiligheidsnormen, inclusief de juiste kabeldikte en stekker. Het gebruik van niet geschikte Kabels en/of Adapters kan een storing of brand veroorzaken. Wetgeving voor Elektrische apparatuur en Materiaalveiligheid verbied het gebruik van UL of CSA -gecertificeerde Kabels (met UL/CSA in de code) voor elke andere toepassing dan de door Supermicro hiervoor beoogde Producten.

# Appendix B

## System Specifications

### Processors

Dual AMD EPYC™ 9004/9005 (Motherboard revision 2.0 or above is required) series processors in Socket SP5

### BIOS

256Mb SPI AMI BIOS® SM Flash UEFI BIOS

ACPI 6.4, SMBIOS 3.5, Plug-and-Play (PnP), RTC (Real Time Clock) wakeup, Riser Card Auto-Detection support

### Memory

Up to 6 TB of ECC DDR5 RDIMM/3DS at 4800 MT/s speed in 24 DIMM slots with AMD EPYC™ 9004 series processors installed

Up to 9 TB of ECC DDR5 RDIMM/3DS at 6000 MT/s speed in 24 DIMM slots with AMD EPYC™ 9005 series processors installed (Motherboard revision 2.0 or above is required)

### Storage Drives

Eight 2.5" SAS/SATA/NVMe drives (additional cables required)

Optional additional four 2.5" SAS/SATA/NVMe drives

Two M.2 NVMe PCIe 3.0 x4 in the 2280 and 22110 form factors for boot drive

### PCI Expansion Slots

Two PCIe 5.0 x16 FH, 10.5"L

One PCIe 5.0 x16 FHHL

### Input/Output

One VGA header

One COM header

Three USB 3.2 Gen1 ports (one front, two rear)

One dedicated BMC LAN

### Motherboard

H13DSH 17" (W) x 11.5" (L), (431.8 x 292.1 mm)

### Chassis

CSE-HS119-R1K24P2-A 1U: 1.7 x 17.2 x 29.4in. / 43 x 437 x 747mm (HxWxD)

### System Cooling

Eight 4-cm heavy duty fans with optimal fan speed control

Two Air Shrouds

### Security

Trusted Platform Module (TPM) support

### Power Supply

Model: PWS-1K24A-1R, 1200W redundant modules, 80Plus Titanium level\*

\*Full redundancy based on configuration and application load

AC Input

800W: 100-127Vac / 9.8A-7A / 50-60Hz

1200W: 200-240Vac / 7.5A-6A / 50-60Hz

+12V

Max: 83A / Min: 0A (100Vac-127Vac)

Max: 100A / Min: 0A (200Vac-240Vac)

12V SB

Max: 2.1A / Min: 0A

**Operating Environment**

Operating Temperature: 10° to 35° C (50° to 95° F)\*

\*Operating Temperature based on configurations

Non-operating Temperature: -40° to 60° C (-40° to 140° F)

Operating Relative Humidity: 8% to 90% (non-condensing)

Non-operating Relative Humidity: 5% to 95% (non-condensing)

**Regulatory Compliance**

FCC, ICES, CE, VCCI, RCM, UKCA, NRTL, CB

**Applied Directives, Standards**

EMC/EMI: 2014/30/EU (EMC Directive)

Electromagnetic Compatibility Regulations 2016

FCC Part 15 Subpart B

ICES-003

VCCI-CISPR 32

AS/NZS CISPR 32

BS/EN55032

BS/EN55035

BS/EN 61000-3-2

BS/EN 61000-3-3

BS/EN 61000-4-2

BS/EN 61000-4-3

BS/EN 61000-4-4

BS/EN 61000-4-5

BS/EN 61000-4-6

BS/EN 61000-4-8

BS/EN 61000-4-11

Environment:

Delegated Directive (EU) 2015/863

Directive 2011/65/EU (RoHS)

REACH Regulation EC 1907/2006

WEEE Directive 2012/19/EU

California Proposition 65

Product Safety: 2014/35/EU (LVD Directive)

Electrical Equipment (Safety) Regulations 2016

UL/CSA 62368-1 (USA and Canada)

BS/IEC/EN 62368-1

**Perchlorate Warning**

California Best Management Practices Regulations for Perchlorate Materials: This Perchlorate warning applies only to products containing CR (Manganese Dioxide) Lithium coin cells. "Perchlorate Material-special handling may apply. See [www.dtsc.ca.gov/hazardouswaste/perchlorate](http://www.dtsc.ca.gov/hazardouswaste/perchlorate)"

この装置は、クラスA機器です。この装置を住宅環境で使用すると電波妨害を引き起こすことがあります。この場合には使用者が適切な対策を講ずるよう要求されることがあります。

VCCI – A